

WE3&WE4&WE5

High Efficiency
Three Phase Asynchronous Motor

www.wolong-electric.com

**BROOK
CROMPTON**
a WOLONG company

Contents

03 Wolong Group

03 Brook Crompton

04 Product Description

06 IE5 Performance data

10 IE4 Performance data

15 IE3 Performance data

20 Motor installation and dimensions B3

24 Motor installation and dimensions B35

28 Motor installation and dimensions B5&V1

32 Motor installation and dimensions B14&V18

34 Technical information

37 Optional accessories

39 Ordering guide

Wolong Group

Wolong, founded in 1984 and headquartered in Shaoxing, Zhejiang Province, is a global leading industrial enterprise committed to providing safe, efficient, smart and green power drive system solutions with life-long supporting services to global users.

By utilizing cutting edge permanent magnet, nanotechnology and silicon carbide technologies, Wolong has built the China's first motor material demonstration platform, that satisfy the highest standards for power density and energy efficiency of motors and generators. With more than 30 years of development, the company has grown into one of the World's top three motor and drive manufacturers and sales enterprises. Wolong insists on technological innovation to lead the industrial reform, actively supports business digital transformation, continuously develops efficient drive system solutions and creates smart industry brain for the motor and drive life cycle management.

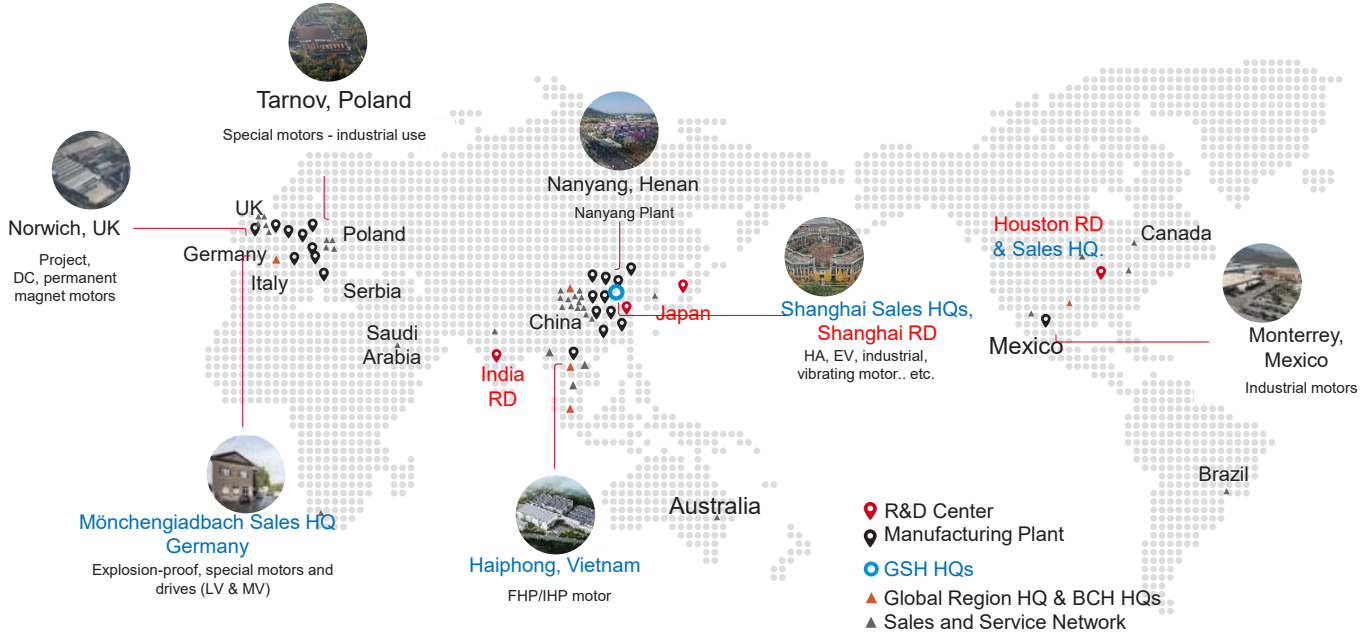

Brook Crompton

Brook Crompton is a global leader in the development of high-efficiency motors. In 1878, it completed the development and production of the first series of high-efficiency motors in the United Kingdom.

It enjoys a good reputation in the electric drive industry in continental Europe, Asia Pacific and North America, and has become the world's leading motor distribution brand.



Product Description

Product Description

WE Series range is a high quality standard range of electric motors with a specification suitable for most industrial applications. The product efficiency meets IEC60034-30-1 IE3 to IE5 grade, mounting dimensions conform to IEC standards, also features a contoured shape, low loss, low noise, low vibration, safe and reliable operation and easy maintenance.



Aluminium motor
Flexible feet
Frame size 63-160



Cast iron motor
Fixed feet
Frame size 80-355

Typical applications

Widely used in pumps, fans, machine tools, reducers, packaging machinery, mining machinery, construction machinery and other types of transmission machinery industry.



▼ Nomenclature

WE5 - 160 M1-2 - X

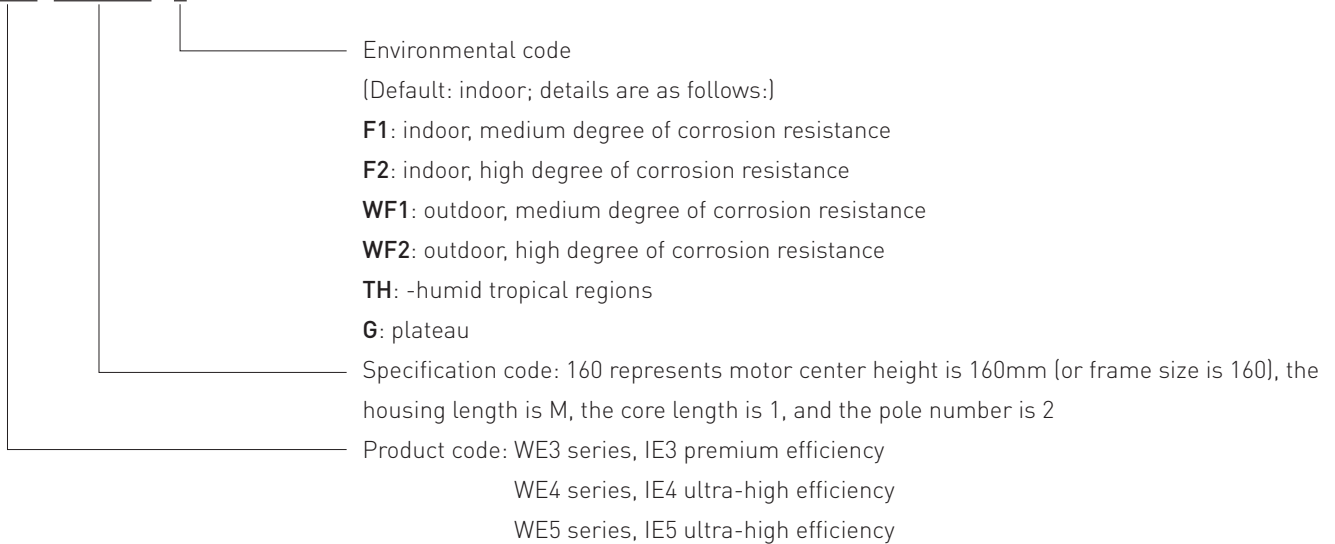

▼ Specification

Specification	Standard product	Option
Frame size	63~355	-
Rated power	0.18~375kW	-
Number of poles	2P, 4P, 6P, 8P	-
Rated voltage	380V	On request
Frequency	50Hz	60 Hz
Duty	S1	S2, S3
Efficiency level	IE3, IE4, IE5	-
Mounting option	B3, B5, B35	B14, B34
Insulation	Class F	Class H
Connection	Below 4kW: "Y" connection 4kW or above: "Δ" connection	-
Thermal protection	-	Thermistors, Thermostats or RTDs
Anti-Condensation heaters	-	110V or 220 to 240V
Enclosure	IP55	IP56, IP65
Cooling type	IC411	IC416, IC418
Frame material	Aluminium: 90 to 160 Cast iron : 80 to 355	-
Terminal box position	Top	Right hand side, left hand side
Located bearing	Drive end	-
Lubrication	80 to 180 Sealed for life bearings	160 to 180 Regreasing
	200 to 355 Regreasing	-
Inverter Duty (with derate)	Variable Torque: 10:1	-
	Constant Torque: 2:1	Alternative speed range
Ambient temperature	-20°C~+40°C	-
Altitude	No more than 1000 m	On request

IE5 Performance data

Cast iron motor-3000 r/min (2 pole) IE5

Model	Power	Rated Current (A)			Speed	Efficiency (%)			Power Factor			Locked Rotor Torque Rated Torque	Locked Rotor Current Rated Current	Maximum Torque Rated Torque	Weight kg	Noise		Moment of Inertia kg·m ²	Torque N·m
	kW	I _n 380V	I _n 400V	I _n 415V	r/min	50%	75%	100%	50%	75%	100%					L _{PA} dB(A)	L _{WA} dB(A)		
WE5-80M1-2	0.75	1.59	1.51	1.46	2875	83.6	86.3	86.3	0.74	0.80	0.83	2.3	10	2.3	20	54	62	0.0053	2.5
WE5-80M2-2	1.1	2.29	2.18	2.10	2885	86.2	87.8	87.8	0.74	0.80	0.83	2.3	9.0	2.3	22	54	62	0.0074	3.65
WE5-90S-2	1.5	3.02	2.87	2.76	2890	86.9	88.9	88.9	0.75	0.82	0.85	2.3	9.0	2.3	27	59	67	0.0095	4.97
WE5-90L-2	2.2	4.31	4.09	3.95	2895	88.1	90.2	90.2	0.76	0.83	0.86	2.3	9.5	2.3	31	59	67	0.018	7.32
WE5-100L-2	3	5.75	5.46	5.27	2900	88.9	91.1	91.1	0.79	0.84	0.87	2.3	9.5	2.3	44	66	74	0.032	9.88
WE5-112M-2	4	7.52	7.15	6.89	2915	90.0	91.8	91.8	0.79	0.86	0.88	2.3	9.5	2.3	54	69	77	0.066	13.2
WE5-132S1-2	5.5	10.3	9.74	9.39	2925	90.8	92.6	92.6	0.79	0.86	0.88	2.2	9.5	2.3	88	71	79	0.077	18.0
WE5-132S2-2	7.5	13.7	13.0	12.6	2925	91.1	93.3	93.3	0.80	0.86	0.89	2.2	9.5	2.3	94	71	79	0.22	24.7
WE5-160M1-2	11	20.0	19.0	18.3	2940	93.0	94.0	94.0	0.79	0.86	0.89	2.2	9.5	2.3	160	73	81	0.26	35.7
WE5-160M2-2	15	27.1	25.7	24.8	2940	93.1	94.5	94.5	0.79	0.86	0.89	2.2	9.5	2.3	177	73	81	0.33	48.9
WE5-160L-2	18.5	33.3	31.6	30.5	2940	93.3	94.9	94.9	0.81	0.87	0.89	2.2	9.5	2.3	195	73	81	0.39	60.3
WE5-180M-2	22	39.5	37.5	36.2	2945	93.6	95.1	95.1	0.81	0.87	0.89	2.2	9.5	2.3	210	75	83	0.66	71.3
WE5-200L1-2	30	53.6	50.9	49.1	2970	94.4	95.5	95.5	0.82	0.87	0.89	2.2	9.0	2.3	280	76	84	0.77	96.5
WE5-200L2-2	37	65.9	62.6	60.4	2970	94.5	95.8	95.8	0.82	0.86	0.89	2.2	9.0	2.3	310	76	84	1.34	119
WE5-225M-2	45	80.0	76.0	73.3	2970	94.7	96.0	96.0	0.83	0.87	0.89	2.2	9.0	2.3	415	78	86	1.63	145
WE5-250M-2	55	97.6	92.7	89.4	2970	94.9	96.2	96.2	0.83	0.87	0.89	2.2	9.0	2.3	490	75	89	1.98	177
WE5-280S-2	75	133	126	121	2980	95.0	96.5	96.5	0.83	0.88	0.89	2.0	8.5	2.3	660	79	91	2.12	241
WE5-280M-2	90	159	151	146	2980	95.2	96.6	96.6	0.84	0.88	0.89	2.0	8.5	2.3	700	79	91	2.37	289
WE5-315S-2	110	194	184	178	2985	95.3	96.8	96.8	0.84	0.88	0.89	1.9	8.5	2.3	1170	79	92	2.54	353
WE5-315M-2	132	233	221	213	2985	95.4	96.9	96.9	0.84	0.88	0.89	1.9	8.5	2.3	1300	79	92	2.86	423
WE5-315L1-2	160	282	268	258	2985	95.6	97.0	97.0	0.85	0.88	0.89	1.9	8.5	2.2	1360	79	92	3.38	513
WE5-315L2-2	185	325	309	298	2985	95.6	97.2	97.2	0.85	0.88	0.89	1.9	8.5	2.2	1410	79	92	3.58	593
WE5-315L3-2	200	351	334	322	2985	95.6	97.2	97.2	0.85	0.88	0.89	1.9	8.5	2.2	1540	79	92	4.05	641
WE5-355M1-2	220	378	359	346	2990	95.6	97.2	97.2	0.87	0.89	0.91	1.8	8.5	2.2	1860	87	100	6.53	705
WE5-355M2-2	250	429	408	393	2990	95.6	97.2	97.2	0.88	0.89	0.91	1.8	8.5	2.2	2200	87	100	6.87	798
WE5-355L1-2	280	481	457	440	2990	95.6	97.2	97.2	0.88	0.89	0.91	1.8	8.5	2.2	2160	87	100	7.30	897
WE5-355L2-2	315	541	514	495	2990	95.7	97.2	97.2	0.88	0.89	0.91	1.8	8.5	2.2	2450	87	100	7.41	1009
WE5-3551-2	355	610	579	558	2990	95.8	97.2	97.2	0.88	0.89	0.91	1.1	8.6	1.8	2450	89	104	7.71	1138
WE5-3552-2	375	651	619	596	2990	95.8	97.2	97.2	0.88	0.89	0.90	1.1	8.6	1.8	2580	89	104	8.01	1202

Cast iron motor-1500 r/min (4 pole) IE5

Model	Power	Rated Current (A)			Speed	Efficiency (%)			Power Factor			Locked Rotor Torque Rated Torque	Locked Rotor Current Rated Current	Maximum Torque Rated Torque	Weight kg	Noise		Moment of Inertia kg·m ²	Torque N·m
	kW	I _N 380V	I _N 400V	I _N 415V	r/min	50%	75%	100%	50%	75%	100%					L _{PA} dB(A)	L _{WA} dB(A)		
WE5-80M1-4	0.55	1.30	1.24	1.19	1425	83.5	86.7	86.7	0.55	0.67	0.74	2.3	10	2.3	21	48	56	0.0074	3.69
WE5-80M2-4	0.75	1.75	1.66	1.60	1425	84.8	88.2	88.2	0.55	0.67	0.74	2.3	8.0	2.3	23	48	56	0.013	5.03
WE5-90S-4	1.1	2.49	2.37	2.28	1430	86.1	89.5	89.5	0.56	0.69	0.75	2.3	8.5	2.3	26	51	59	0.016	7.35
WE5-90L-4	1.5	3.23	3.07	2.96	1430	87.4	90.4	90.4	0.60	0.72	0.78	2.3	8.5	2.3	34	51	59	0.033	10.1
WE5-100L1-4	2.2	4.63	4.40	4.24	1435	88.5	91.4	91.4	0.62	0.73	0.79	2.3	9.0	2.3	42	56	64	0.041	14.5
WE5-100L2-4	3	6.19	5.88	5.66	1440	89.1	92.1	92.1	0.63	0.74	0.80	2.3	9.0	2.3	53	56	64	0.062	20.2
WE5-112M-4	4	8.19	7.78	7.50	1450	89.9	92.8	92.8	0.67	0.75	0.80	2.3	9.0	2.3	57	57	65	0.12	26.3
WE5-132S-4	5.5	11.2	10.6	10.2	1460	90.7	93.4	93.4	0.67	0.77	0.80	2.0	9.5	2.3	87	63	71	0.18	36.0
WE5-132M-4	7.5	15.0	14.2	13.7	1460	91.6	94.0	94.0	0.69	0.79	0.81	2.0	9.5	2.3	105	63	71	0.38	49.6
WE5-160M-4	11	21.3	20.2	19.5	1470	92.4	94.6	94.6	0.71	0.81	0.83	2.0	9.5	2.3	170	65	73	0.44	71.5
WE5-160L-4	15	28.5	27.1	26.1	1470	92.9	95.1	95.1	0.73	0.81	0.84	2.0	9.5	2.3	200	65	73	0.71	97.4
WE5-180M-4	18.5	34.7	33.0	31.8	1475	92.8	95.3	95.3	0.75	0.82	0.85	2.0	9.5	2.3	210	68	76	0.76	120
WE5-180L-4	22	41.2	39.1	37.7	1475	93.2	95.5	95.5	0.75	0.82	0.85	2.0	9.5	2.3	235	68	76	0.85	142
WE5-200L-4	30	55.9	53.1	51.2	1475	94.1	95.9	95.9	0.76	0.82	0.85	2.0	9.0	2.3	300	68	76	1.27	194
WE5-225S-4	37	68.8	65.4	63.0	1480	94.3	96.1	96.1	0.77	0.82	0.85	2.0	9.0	2.3	400	70	78	1.94	239
WE5-225M-4	45	83.5	79.4	76.5	1480	94.7	96.3	96.3	0.76	0.83	0.85	2.0	9.0	2.3	440	70	78	2.44	290
WE5-250M-4	55	101	95.7	92.2	1480	95.0	96.5	96.5	0.78	0.84	0.86	2.0	9.0	2.3	550	67	79	3.00	355
WE5-280S-4	75	135	129	124	1485	95.1	96.7	96.7	0.78	0.85	0.87	2.0	8.5	2.3	700	68	80	3.51	484
WE5-280M-4	90	160	152	147	1485	95.6	96.9	96.9	0.79	0.86	0.88	2.0	8.5	2.3	800	68	80	4.91	579
WE5-315S-4	110	194	184	177	1490	95.8	97.0	97.0	0.79	0.86	0.89	2.0	8.5	2.2	1200	75	88	5.21	707
WE5-315M-4	132	232	220	213	1490	96.1	97.1	97.1	0.80	0.87	0.89	2.0	8.5	2.2	1300	75	88	5.48	849
WE5-315L1-4	160	278	264	254	1490	96.2	97.2	97.2	0.85	0.87	0.90	2.0	8.5	2.2	1320	75	88	5.70	1029
WE5-315L2-4	185	321	305	294	1490	96.3	97.4	97.4	0.85	0.87	0.90	2.0	8.5	2.2	1360	75	88	5.90	1190
WE5-315L3-4	200	347	329	317	1490	96.3	97.4	97.4	0.86	0.88	0.90	2.0	8.5	2.2	1600	75	88	6.77	1286
WE5-355M1-4	220	381	362	349	1495	96.3	97.4	97.4	0.85	0.87	0.90	2.0	8.5	2.2	2100	82	95	7.58	1405
WE5-355M2-4	250	433	412	397	1495	96.4	97.4	97.4	0.86	0.88	0.90	2.0	8.5	2.2	2100	82	95	7.83	1597
WE5-355L1-4	280	485	461	444	1495	96.4	97.4	97.4	0.86	0.88	0.90	2.0	8.5	2.2	2220	82	95	8.06	1789
WE5-355L2-4	315	546	519	500	1495	96.5	97.4	97.4	0.86	0.88	0.90	2.0	8.5	2.2	2400	82	95	8.19	2012
WE5-3551-4	355	615	585	563	1495	96.5	97.4	97.4	0.86	0.88	0.90	1.7	8.5	2.2	2420	87	102	8.53	2275
WE5-3552-4	375	650	617	595	1495	96.5	97.4	97.4	0.88	0.88	0.90	1.7	8.5	2.2	2620	87	102	8.96	2395

Cast iron motor-1000 r/min (6 pole) IE5

Model	Power	Rated Current (A)			Speed	Efficiency (%)			Power Factor			Locked Rotor Torque Rated Torque	Locked Rotor Current Rated Current	Maximum Torque Rated Torque	Weight	Noise		Moment of Inertia	Torque
	kW	I _n 380V	I _n 400V	I _n 415V	r/min	50%	75%	100%	50%	75%	100%				kg	LPA dB(A)	LWA dB(A)		
WE5-80M1-6	0.37	1.01	0.96	0.93	930	76.9	81.6	81.6	0.49	0.61	0.68	1.9	10	2.0	18	46	54	0.0074	3.82
WE5-80M2-6	0.55	1.42	1.35	1.30	930	82.5	84.2	84.2	0.51	0.63	0.70	1.9	9.0	2.1	22	46	54	0.013	5.68
WE5-90S-6	0.75	1.90	1.80	1.74	940	83.2	85.7	85.7	0.51	0.63	0.70	2.1	8.5	2.1	33	49	57	0.016	7.62
WE5-90L-6	1.1	2.74	2.60	2.51	945	84.7	87.2	87.2	0.52	0.64	0.70	2.1	7.8	2.1	42	49	57	0.033	11.1
WE5-100L-6	1.5	3.63	3.45	3.32	950	85.4	88.4	88.4	0.56	0.66	0.71	2.1	8.0	2.1	48	53	61	0.045	14.9
WE5-112M-6	2.2	5.25	4.99	4.81	950	86.3	89.7	89.7	0.56	0.66	0.71	2.1	8.0	2.1	65	57	65	0.441	22.1
WE5-132S-6	3	7.09	6.73	6.49	960	87.6	90.6	90.6	0.57	0.66	0.71	2.0	7.5	2.1	76	61	69	0.71	29.8
WE5-132M1-6	4	9.24	8.77	8.46	960	88.4	91.4	91.4	0.59	0.67	0.72	2.0	8.0	2.1	85	61	69	0.80	39.8
WE5-132M2-6	5.5	12.6	12.0	11.5	965	89.1	92.2	92.2	0.59	0.67	0.72	2.0	8.0	2.1	95	61	69	0.85	54.4
WE5-160M-6	7.5	16.1	15.3	14.8	970	89.8	92.9	92.9	0.61	0.72	0.76	2.1	8.0	2.1	150	65	73	1.27	73.8
WE5-160L-6	11	23.2	22.0	21.2	970	90.8	93.7	93.7	0.62	0.73	0.77	2.1	8.5	2.1	185	65	73	1.39	108
WE5-180L-6	15	30.2	28.7	27.7	975	92.0	94.3	94.3	0.68	0.76	0.80	2.0	8.5	2.1	235	65	73	1.70	147
WE5-200L1-6	18.5	37.1	35.3	34.0	980	92.4	94.6	94.6	0.68	0.76	0.80	2.1	8.5	2.1	210	65	73	1.93	180
WE5-200L2-6	22	43.5	41.3	39.8	980	92.6	94.9	94.9	0.70	0.77	0.81	2.1	8.5	2.1	240	65	73	2.55	214
WE5-225M-6	30	58.3	55.4	53.4	980	92.9	95.3	95.3	0.71	0.81	0.82	2.0	8.3	2.1	375	66	74	2.81	292
WE5-250M-6	37	70.8	67.3	64.9	985	93.7	95.6	95.6	0.71	0.81	0.83	2.1	8.3	2.1	460	64	76	3.63	361
WE5-280S-6	45	86.0	81.7	78.7	985	93.7	95.8	95.8	0.72	0.81	0.83	2.1	8.5	2.0	605	66	78	4.17	439
WE5-280M-6	55	104	98.4	94.9	985	93.8	96.0	96.0	0.73	0.81	0.84	2.0	8.5	2.0	660	66	78	4.80	536
WE5-315S-6	75	141	134	129	990	95.2	96.3	96.3	0.74	0.81	0.84	2.0	8.0	2.0	1320	70	83	5.07	727
WE5-315M-6	90	167	158	153	990	95.4	96.5	96.5	0.74	0.81	0.85	2.0	8.0	2.0	1450	70	83	5.59	873
WE5-315L1-6	110	204	193	186	990	95.6	96.6	96.6	0.74	0.81	0.85	2.0	8.0	2.0	1480	70	83	6.25	1066
WE5-315L2-6	132	241	229	221	990	95.7	96.8	96.8	0.74	0.83	0.86	2.0	8.0	2.0	1580	70	83	7.69	1280
WE5-355M1-6	160	292	277	267	995	96.2	96.9	96.9	0.76	0.84	0.86	1.9	8.0	2.0	2100	72	85	8.28	1551
WE5-355M2-6	185	337	320	309	995	96.2	97.0	97.0	0.76	0.84	0.86	1.9	8.0	2.0	2150	72	85	8.58	1793
WE5-355M3-6	200	364	346	334	995	96.2	97.0	97.0	0.76	0.84	0.86	1.9	8.0	2.0	2150	72	85	8.66	1939
WE5-355L1-6	220	396	376	363	995	96.2	97.0	97.0	0.82	0.85	0.87	1.9	8.0	2.0	2200	72	85	8.78	2112
WE5-355L2-6	250	455	433	417	995	96.2	97.0	97.0	0.82	0.85	0.86	1.9	8.0	2.0	2330	72	85	8.80	2424
WE5-3551-6	280	535	508	490	995	96.2	97.0	97.0	0.70	0.77	0.82	1.6	8.0	2.0	2280	76	91	8.94	2687
WE5-3552-6	315	602	572	551	995	96.2	97.0	97.0	0.72	0.78	0.82	1.6	8.0	2.0	2480	76	91	9.08	3054

Cast iron motor-750 r/min (8 pole) IE5

Model	Power	Rated Current (A)			Speed	Efficiency (%)			Power Factor			Locked Rotor Torque	Locked Rotor Current	Maximum Torque	Weight	Noise		Moment of Inertia	Torque
	kW	I _n 380V	I _n 400V	I _n 415V	r/min	50%	75%	100%	50%	75%	100%					kg	LPA dB(A)		
WE5-80M1-8	0.18	0.62	0.59	0.57	695	66.5	71.9	71.9	0.43	0.54	0.61	1.8	7.5	1.9	16	44	52	0.0074	2.47
WE5-80M2-8	0.25	0.83	0.79	0.76	695	69.4	75.2	75.2	0.43	0.54	0.61	1.8	7.9	2.0	19	44	52	0.013	3.43
WE5-90S-8	0.37	1.18	1.12	1.08	700	72.5	78.4	78.4	0.44	0.55	0.61	1.8	8.3	2.0	30	48	56	0.016	5.05
WE5-90L-8	0.55	1.70	1.61	1.56	700	73.8	80.6	80.6	0.44	0.55	0.61	1.8	7.4	2.0	35	48	56	0.033	7.5
WE5-100L1-8	0.75	2.11	2.00	1.93	710	70.3	82.0	82.0	0.49	0.60	0.66	1.8	7.4	2.0	42	51	59	0.045	10.1
WE5-100L2-8	1.1	2.97	2.82	2.72	710	81.9	84.0	84.0	0.50	0.61	0.67	1.8	7.1	2.0	50	51	59	0.047	14.8
WE5-112M-8	1.5	3.86	3.67	3.54	710	83.4	85.5	85.5	0.52	0.63	0.69	1.8	7.2	2.0	50	53	61	0.29	20.2
WE5-132S-8	2.2	5.48	5.20	5.01	720	85.1	87.2	87.2	0.54	0.64	0.70	1.9	7.4	2.0	65	56	64	0.32	29.2
WE5-132M-8	3	7.37	7.00	6.74	720	86.3	88.4	88.4	0.54	0.64	0.70	1.9	7.8	2.0	80	56	64	0.34	39.8
WE5-160M1-8	4	9.57	9.10	8.77	730	88.1	89.4	89.4	0.56	0.65	0.71	1.9	7.9	2.0	125	60	68	0.48	52.3
WE5-160M2-8	5.5	12.8	12.2	11.8	730	89.1	90.4	90.4	0.57	0.66	0.72	2.0	8.1	2.0	135	60	68	0.64	71.9
WE5-160L-8	7.5	16.9	16.0	15.4	730	90.0	91.3	91.3	0.59	0.67	0.74	2.0	7.8	2.0	160	60	68	1.11	98.1
WE5-180L-8	11	24.5	23.3	22.4	735	91.3	92.2	92.2	0.59	0.67	0.74	1.9	7.9	2.0	190	62	70	1.68	143
WE5-200L-8	15	32.7	31.1	30.0	735	91.8	92.9	92.9	0.61	0.70	0.75	1.9	8.0	2.0	220	65	73	2.39	195
WE5-225S-8	18.5	40.2	38.2	36.8	740	92.2	93.3	93.3	0.61	0.70	0.75	1.9	8.0	2.0	310	65	73	2.88	238
WE5-225M-8	22	47.0	44.6	43.0	740	92.6	93.6	93.6	0.62	0.71	0.76	1.9	8.3	2.0	360	65	73	3.85	284
WE5-250M-8	30	62.9	59.8	57.6	740	93.0	94.1	94.1	0.64	0.72	0.77	1.9	7.8	2.0	400	63	75	5.42	387
WE5-280S-8	37	76.3	72.5	69.9	740	93.4	94.4	94.4	0.64	0.73	0.78	1.8	7.9	2.0	550	64	76	6.11	477
WE5-280M-8	45	92.6	87.9	84.8	740	93.6	94.7	94.7	0.65	0.73	0.78	1.8	7.9	2.0	600	64	76	7.08	580
WE5-315S-8	55	110	105	101	745	94.0	94.9	94.9	0.69	0.75	0.80	1.8	8.1	2.0	1140	69	82	7.72	705
WE5-315M-8	75	149	142	137	745	94.4	95.3	95.3	0.69	0.75	0.80	1.8	7.6	2.0	1180	69	82	9.23	961
WE5-315L1-8	90	177	168	162	745	94.4	95.5	95.5	0.71	0.77	0.81	1.8	7.7	2.0	1350	69	82	9.64	1154
WE5-315L2-8	110	216	205	197	745	94.6	95.7	95.7	0.71	0.77	0.81	1.8	7.7	2.0	1480	69	82	10.7	1410
WE5-355M1-8	132	258	245	236	745	94.8	95.9	95.9	0.72	0.78	0.81	1.8	7.8	2.0	1900	75	90	11.8	1692
WE5-355M2-8	160	308	293	282	745	95.1	96.1	96.1	0.74	0.80	0.82	1.8	7.8	2.0	2050	75	90	13.1	2051
WE5-355L-8	200	385	366	352	745	95.2	96.3	96.3	0.74	0.80	0.82	1.8	7.8	2.0	2200	75	90	14.4	2563

IE4 Performance data

Cast iron motor-3000 r/min (2 pole) IE4

Model	Power	Rated Current (A)			Speed	Efficiency (%)			Power Factor			Locked Rotor Torque Rated Torque	Locked Rotor Current Rated Current	Maximum Torque Rated Torque	Weight	Noise		Moment of Inertia	Torque
	kW	I _n 380V	I _n 400V	I _n 415V	r/min	50%	75%	100%	50%	75%	100%				kg	L _{PA} dB(A)	L _{WA} dB(A)		
WE4-80M1-2	0.75	1.64	1.56	1.51	2875	83.2	83.3	83.5	0.74	0.80	0.83	2.2	8.5	2.3	18	50	62	0.001	2.49
WE4-80M2-2	1.1	2.36	2.25	2.16	2885	84.9	85.5	85.2	0.74	0.80	0.83	2.2	8.5	2.3	19	50	62	0.0014	3.64
WE4-90S-2	1.5	3.1	2.94	2.84	2890	86.2	87.1	86.5	0.75	0.82	0.85	2.2	9.0	2.3	26	55	67	0.0015	4.96
WE4-90L-2	2.2	4.42	4.2	4.04	2895	87.7	88.4	88.0	0.76	0.83	0.86	2.2	9.0	2.3	30	55	67	0.0017	7.3
WE4-100L-2	3	5.9	5.6	5.4	2900	88.8	89.7	89.1	0.79	0.84	0.87	2.2	9.5	2.3	38	62	74	0.0055	9.9
WE4-112M-2	4	7.7	7.3	7	2915	89.7	90.6	90.0	0.79	0.86	0.88	2.2	9.5	2.3	51	65	77	0.0075	13.1
WE4-132S1-2	5.5	10.4	9.9	9.6	2925	90.6	91.2	90.9	0.79	0.86	0.88	2.0	9.5	2.3	73	67	79	0.015	18
WE4-132S2-2	7.5	14	13.3	12.8	2925	91.4	92.3	91.7	0.80	0.86	0.89	2.0	9.5	2.3	80	67	79	0.019	24.5
WE4-160M1-2	11	20.3	19.3	18.6	2940	92.3	92.9	92.6	0.79	0.86	0.89	2.0	9.5	2.3	132	68	81	0.05	35.7
WE4-160M2-2	15	27.4	26.1	25.1	2940	92.9	93.5	93.3	0.79	0.86	0.89	2.0	9.5	2.3	140	68	81	0.059	48.7
WE4-160L-2	18.5	33.7	32	30.9	2940	93.4	94.1	93.7	0.81	0.87	0.89	2.0	9.5	2.3	155	68	81	0.069	60
WE4-180M-2	22	40	38	36.6	2945	93.7	94.3	94.0	0.81	0.87	0.89	2.0	9.5	2.3	195	70	83	0.1	71
WE4-200L1-2	30	54	51	49.6	2970	94.1	94.3	94.5	0.82	0.87	0.89	2.0	9.0	2.3	256	71	84	0.2	96
WE4-200L2-2	37	67	63	61	2970	94.2	94.7	94.8	0.82	0.86	0.89	2.0	9.0	2.3	285	71	84	0.24	119
WE4-225M-2	45	81	77	74	2970	94.6	94.9	95.0	0.83	0.87	0.89	2.0	9.0	2.3	345	73	86	0.39	145
WE4-250M-2	55	99	94	90	2970	94.9	95.3	95.3	0.83	0.87	0.89	2.0	9.0	2.3	450	75	89	0.49	177
WE4-280S-2	75	134	127	123	2980	95.3	95.6	95.6	0.83	0.88	0.89	1.8	8.5	2.3	588	77	91	0.86	240
WE4-280M-2	90	160	152	147	2980	95.5	95.8	95.8	0.84	0.88	0.89	1.8	8.5	2.3	660	77	91	1.1	288
WE4-315S-2	110	196	186	179	2985	95.7	96.0	96.0	0.84	0.88	0.89	1.8	8.5	2.3	960	78	92	1.5	352
WE4-315M-2	132	234	223	214	2985	95.9	96.2	96.2	0.84	0.88	0.89	1.8	8.5	2.3	1060	78	92	1.6	422
WE4-315L1-2	160	284	269	260	2985	96.0	96.3	96.3	0.85	0.88	0.89	1.8	8.5	2.2	1185	78	92	2.1	512
WE4-315L2-2	185	328	311	300	2985	96.1	96.4	96.4	0.85	0.88	0.89	1.8	8.5	2.2	1320	78	92	2.3	592
WE4-315L3-2	200	354	336	324	2985	96.2	96.5	96.5	0.85	0.88	0.89	1.8	8.5	2.2	1320	78	92	2.5	640
WE4-355M1-2	220	381	362	349	2990	96.2	96.5	96.5	0.87	0.89	0.91	1.6	8.5	2.2	1870	85	100	4.2	703
WE4-355M2-2	250	433	411	396	2990	96.2	96.5	96.5	0.88	0.89	0.91	1.6	8.5	2.2	1950	85	100	4.9	798
WE4-355L1-2	280	484	460	444	2990	96.2	96.5	96.5	0.88	0.89	0.91	1.6	8.5	2.2	2080	85	100	4.7	894
WE4-355L2-2	315	545	518	499	2990	96.2	96.5	96.5	0.88	0.89	0.91	1.6	8.5	2.2	2100	85	100	6	1006
WE4-3551-2	355	614	583	562	2990	96.2	96.5	96.5	0.88	0.89	0.91	0.9	8.6	1.8	2220	89	104	6.8	1134

Cast iron motor-1500 r/min (4 pole) IE4

Model	Power	Rated Current (A)			Speed	Efficiency (%)			Power Factor			Locked Rotor Torque Rated Torque	Locked Rotor Current Rated Current	Maximum Torque Rated Torque	Weight	Noise		Moment of Inertia	Torque
	kW	I _n 380V	I _n 400V	I _n 415V	r/min	50%	75%	100%	50%	75%	100%				kg	L _{PA} dB(A)	L _{WA} dB(A)		
WE4-80M1-4	0.55	1.35	1.28	1.23	1425	82.8	84.2	83.9	0.55	0.67	0.74	2.4	9.8	2.2	18	44	56	0.002	3.69
WE4-80M2-4	0.75	1.8	1.71	1.65	1425	84.5	86.1	85.7	0.55	0.67	0.74	2.3	8.5	2.3	20	44	56	0.0026	5
WE4-90S-4	1.1	2.56	2.43	2.34	1430	86.5	87.6	87.2	0.56	0.69	0.75	2.3	8.5	2.3	25	47	59	0.0037	7.3
WE4-90L-4	1.5	3.31	3.15	3.03	1430	87.5	88.5	88.2	0.60	0.72	0.78	2.3	9.0	2.3	30	47	59	0.0047	10
WE4-100L1-4	2.2	4.73	4.49	4.33	1435	89.2	89.7	89.5	0.62	0.73	0.79	2.3	9.0	2.3	38	52	64	0.011	14.6
WE4-100L2-4	3	6.3	6	5.8	1440	90.1	90.7	90.4	0.63	0.74	0.80	2.3	9.5	2.3	42	52	64	0.015	19.9
WE4-112M-4	4	8.3	7.9	7.6	1450	90.8	91.4	91.1	0.67	0.75	0.80	2.2	9.5	2.3	55	53	65	0.022	26.3
WE4-132S-4	5.5	11.4	10.8	10.4	1460	91.6	92.1	91.9	0.67	0.77	0.80	2.0	9.5	2.3	77	59	71	0.035	36
WE4-132M-4	7.5	15.2	14.4	13.9	1460	92.3	92.9	92.6	0.69	0.79	0.81	2.0	9.5	2.3	82	59	71	0.04	49.1
WE4-160M-4	11	21.6	20.5	19.8	1470	93.0	93.5	93.3	0.71	0.81	0.83	2.2	9.5	2.3	136	60	73	0.098	71
WE4-160L-4	15	28.9	27.4	26.5	1470	93.6	94.2	93.9	0.73	0.81	0.84	2.2	9.5	2.3	155	60	73	0.12	97
WE4-180M-4	18.5	35.1	33.3	32.1	1475	93.9	94.5	94.2	0.75	0.82	0.85	2.0	9.5	2.3	190	63	76	0.19	120
WE4-180L-4	22	41.6	39.5	38.1	1475	94.2	94.5	94.5	0.75	0.82	0.85	2.0	9.5	2.3	210	63	76	0.22	142
WE4-200L-4	30	57	54	52	1475	94.5	94.9	94.9	0.76	0.82	0.85	2.0	9.0	2.3	285	63	76	0.46	194
WE4-225S-4	37	69	66	64	1480	94.7	95.2	95.2	0.77	0.82	0.85	2.0	9.0	2.3	350	65	78	0.5	239
WE4-225M-4	45	84	80	77	1480	94.9	95.4	95.4	0.76	0.83	0.85	2.0	9.0	2.3	385	65	78	0.58	290
WE4-250M-4	55	102	96	93	1480	95.2	95.7	95.7	0.78	0.84	0.86	2.0	9.0	2.3	510	65	79	0.92	355
WE4-280S-4	75	136	130	125	1485	95.7	96.0	96.0	0.78	0.85	0.87	2.0	8.5	2.3	631	66	80	1.5	482
WE4-280M-4	90	162	154	148	1485	95.8	96.1	96.1	0.79	0.86	0.88	2.0	8.5	2.3	716	66	80	1.8	579
WE4-315S-4	110	195	185	179	1490	96.0	96.3	96.3	0.79	0.86	0.89	2.0	8.5	2.2	1010	74	88	3.1	705
WE4-315M-4	132	234	222	214	1490	96.1	96.4	96.4	0.80	0.87	0.89	2.0	8.5	2.2	1080	74	88	3.4	846
WE4-315L1-4	160	280	266	256	1490	96.3	96.6	96.6	0.85	0.87	0.90	2.0	8.5	2.2	1160	74	88	4.1	1026
WE4-315L2-4	185	323	307	296	1490	96.4	96.7	96.7	0.85	0.87	0.90	2.0	8.5	2.2	1275	74	88	5.3	1186
WE4-315L3-4	200	349	332	320	1490	96.4	96.7	96.7	0.86	0.88	0.90	2.0	8.5	2.2	1275	74	88	5.4	1282
WE4-355M1-4	220	384	365	352	1495	96.4	96.7	96.7	0.85	0.87	0.90	2.0	8.5	2.2	1850	80	95	9.3	1405
WE4-355M2-4	250	436	415	400	1495	96.4	96.7	96.7	0.86	0.88	0.90	2.0	8.5	2.2	1850	80	95	9.5	1597
WE4-355L1-4	280	489	464	448	1495	96.5	96.7	96.7	0.86	0.88	0.90	2.0	8.5	2.2	2040	80	95	11	1789
WE4-355L2-4	315	550	522	504	1495	96.5	96.7	96.7	0.86	0.88	0.90	2.0	8.5	2.2	2040	80	95	11	2012
WE4-355L3-4	355	620	589	567	1495	96.5	96.7	96.7	0.86	0.88	0.90	1.7	8.5	2.2	2100	87	102	12	2268

▼ Cast iron motor-1000 r/min (6 pole) IE4

Model	Power	Rated Current (A)			Speed	Efficiency (%)			Power Factor			Locked Rotor Torque Rated Torque	Locked Rotor Current Rated Current	Maximum Torque Rated Torque	Weight	Noise		Moment of Inertia kg·m ²	Torque N.m
	kW	I _n 380V	I _n 400V	I _n 415V	r/min	50%	75%	100%	50%	75%	100%				kg	LPA dB(A)	LWA dB(A)		
WE4-80M1-6	0.37	1.06	1.01	0.97	930	77.1	78.8	78.0	0.49	0.61	0.68	2.0	9.7	2.1	17	42	54	0.0023	3.8
WE4-80M2-6	0.55	1.48	1.4	1.35	930	80.3	81.7	80.9	0.51	0.63	0.70	2.0	9.0	2.1	20	42	54	0.0036	5.6
WE4-90S-6	0.75	1.97	1.87	1.8	940	82.4	83.5	82.7	0.51	0.63	0.70	2.0	7.5	2.1	29	42	57	0.0061	7.6
WE4-90L-6	1.1	2.83	2.68	2.59	945	84.1	85.3	84.5	0.52	0.64	0.70	2.0	7.5	2.1	34	45	57	0.0079	11.1
WE4-100L-6	1.5	3.74	3.55	3.42	950	84.9	86.7	85.9	0.56	0.66	0.71	2.0	7.5	2.1	42	49	61	0.014	15.1
WE4-112M-6	2.2	5.4	5.1	4.93	950	86.7	88.2	87.4	0.56	0.66	0.71	2.0	7.5	2.1	51	53	65	0.023	22.1
WE4-132S-6	3	7.2	6.9	6.6	960	88.2	88.9	88.6	0.57	0.66	0.71	2.0	7.5	2.1	70	57	69	0.029	29.8
WE4-132M1-6	4	9.4	9	8.6	960	88.9	89.8	89.5	0.59	0.67	0.72	2.0	8.0	2.1	78	57	69	0.038	39.8
WE4-132M2-6	5.5	12.8	12.2	11.7	965	89.7	90.8	90.5	0.59	0.67	0.72	2.0	8.0	2.1	85	57	69	0.054	54
WE4-160M-6	7.5	16.4	15.6	15	970	90.8	91.6	91.3	0.61	0.72	0.76	2.0	8.0	2.1	136	60	73	0.13	74
WE4-160L-6	11	23.5	22.3	21.5	970	91.7	92.4	92.3	0.62	0.73	0.77	2.0	8.5	2.1	156	60	73	0.19	108
WE4-180L-6	15	30.7	29.1	28.1	975	92.3	92.9	92.9	0.68	0.76	0.80	2.0	8.5	2.1	210	60	73	0.3	147
WE4-200L1-6	18.5	37.6	35.7	34.4	980	92.9	93.4	93.4	0.68	0.76	0.80	2.0	8.5	2.1	230	60	73	0.4	180
WE4-200L2-6	22	44	41.8	40.3	980	93.2	93.7	93.7	0.70	0.77	0.81	2.0	8.5	2.1	260	60	73	0.52	214
WE4-225M-6	30	59	56	54	980	93.7	94.2	94.2	0.71	0.81	0.82	2.0	8.3	2.1	340	61	74	1.1	292
WE4-250M-6	37	72	68	66	985	93.9	94.5	94.5	0.71	0.81	0.83	2.0	8.3	2.1	445	62	76	1.4	359
WE4-280S-6	45	87	83	80	985	93.9	94.8	94.8	0.72	0.81	0.83	2.0	8.5	2.0	595	64	78	2.8	436
WE4-280M-6	55	105	99	96	985	94.2	95.1	95.1	0.73	0.81	0.84	2.0	8.5	2.0	645	64	78	3.5	533
WE4-315S-6	75	142	135	130	990	94.7	95.4	95.4	0.74	0.81	0.84	1.6	8.0	2.0	985	69	83	3.8	723
WE4-315M-6	90	168	160	154	990	94.9	95.6	95.6	0.74	0.81	0.85	1.6	8.0	2.0	1100	69	83	4.5	868
WE4-315L1-6	110	205	195	188	990	94.9	95.8	95.8	0.74	0.81	0.85	1.6	8.0	2.0	1180	69	83	5.5	1061
WE4-315L2-6	132	243	231	222	990	95.1	96.0	96.0	0.74	0.83	0.86	1.6	8.0	2.0	1310	69	83	6.5	1273
WE4-355M1-6	160	294	279	269	995	95.7	96.2	96.2	0.76	0.84	0.86	1.6	8.0	2.0	1840	70	85	10	1536
WE4-355M2-6	185	339	322	311	995	95.8	96.3	96.3	0.76	0.84	0.86	1.6	8.0	2.0	2030	70	85	13	1776
WE4-355M3-6	200	367	349	336	995	95.8	96.3	96.3	0.76	0.84	0.86	1.6	8.0	2.0	2030	70	85	13	1920
WE4-355L1-6	220	399	379	365	995	95.9	96.4	96.4	0.82	0.85	0.87	1.6	8.0	2.0	2240	76	85	14	2112
WE4-355L2-6	250	458	435	419	995	96.0	96.5	96.5	0.82	0.85	0.86	1.6	8.0	2.0	2240	76	85	15	2399
WE4-3551-6	280	538	511	492	995	96.0	96.5	96.5	0.70	0.77	0.82	1.6	8.0	2.0	2345	76	91	16	2687

Cast iron motor-750 r/min (8 pole) IE4

Model	Power	Rated Current (A)			Speed	Efficiency (%)			Power Factor			Locked Rotor Torque Rated Torque	Locked Rotor Current Rated Current	Maximum Torque Rated Torque	Weight	Noise		Moment of Inertia	Torque
	kW	I _n 380V	I _n 400V	I _n 415V	r/min	50%	75%	100%	50%	75%	100%				kg	LPA dB(A)	LWA dB(A)		
WE4-80M1-8	0.18	0.67	0.63	0.61	695	64.7	66.4	67.2	0.43	0.54	0.61	2.0	7.5	1.9	15	40	52	0.0021	2.47
WE4-80M2-8	0.25	0.88	0.84	0.81	695	68.3	70.0	70.8	0.43	0.54	0.61	2.0	7.9	1.9	17	40	52	0.0023	3.44
WE4-90S-8	0.37	1.24	1.18	1.14	700	71.8	73.4	74.3	0.44	0.55	0.61	2.0	8.3	1.9	27	44	56	0.0062	5
WE4-90L-8	0.55	1.78	1.69	1.63	700	74.5	76.1	77.0	0.44	0.55	0.61	2.0	7.4	2.0	30	44	56	0.0081	7.5
WE4-100L1-8	0.75	2.2	2.09	2.02	710	75.9	86.2	78.4	0.49	0.60	0.66	2.0	7.0	2.0	36	47	59	0.011	10.1
WE4-100L2-8	1.1	3.09	2.93	2.83	710	78.3	81.8	80.8	0.50	0.61	0.67	2.0	7.0	2.0	40	47	59	0.012	14.8
WE4-112M-8	1.5	4	3.8	3.66	710	81.4	83.5	82.6	0.52	0.63	0.69	2.0	7.0	2.0	47	49	61	0.022	20.2
WE4-132S-8	2.2	5.7	5.4	5.2	720	83.3	85.3	84.5	0.54	0.64	0.70	1.8	7.5	2.0	62	52	64	0.027	29.2
WE4-132M-8	3	7.6	7.2	6.9	720	84.7	86.7	85.9	0.54	0.64	0.70	1.8	7.8	2.0	73	52	64	0.03	39.8
WE4-160M1-8	4	9.8	9.3	9	730	86.0	87.5	87.1	0.56	0.65	0.71	1.8	7.9	2.0	115	55	68	0.12	52
WE4-160M2-8	5.5	13.1	12.5	12	730	87.4	88.7	88.3	0.57	0.66	0.72	1.8	8.1	2.0	126	55	68	0.13	72
WE4-160L-8	7.5	17.2	16.4	15.8	730	88.4	89.7	89.3	0.59	0.67	0.74	1.8	7.8	2.0	148	55	68	0.18	98
WE4-180L-8	11	25	23.7	22.9	735	89.5	90.4	90.4	0.59	0.67	0.74	1.8	7.9	2.0	195	57	70	0.28	143
WE4-200L-8	15	33.3	31.7	30.5	735	90.1	91.2	91.2	0.61	0.70	0.75	1.8	8.0	2.0	245	60	73	0.42	195
WE4-225S-8	18.5	40.9	38.8	37.4	740	90.6	91.7	91.7	0.61	0.70	0.75	1.8	8.1	2.0	285	60	73	0.55	239
WE4-225M-8	22	47.8	45.4	43.7	740	91.1	92.1	92.1	0.62	0.71	0.76	1.8	8.3	2.0	325	60	73	1	284
WE4-250M-8	30	64	61	58	740	91.6	92.7	92.7	0.64	0.72	0.77	1.8	7.9	2.0	420	61	75	1.4	387
WE4-280S-8	37	77	74	71	740	92.1	93.1	93.1	0.64	0.73	0.78	1.8	7.9	2.0	550	62	76	2.8	478
WE4-280M-8	45	94	89	86	740	92.3	93.4	93.4	0.65	0.73	0.78	1.8	7.9	2.0	605	62	76	3.5	581
WE4-315S-8	55	111	106	102	745	92.8	93.7	93.7	0.69	0.75	0.80	1.6	8.2	2.0	960	68	82	3.6	705
WE4-315M-8	75	151	144	138	745	93.3	94.2	94.2	0.69	0.75	0.80	1.6	7.6	2.0	1040	68	82	4.4	961
WE4-315L1-8	90	179	170	164	745	93.3	94.4	94.4	0.71	0.77	0.81	1.6	7.7	2.0	1160	68	82	5.4	1154
WE4-315L2-8	110	218	207	200	745	93.6	94.7	94.7	0.71	0.77	0.81	1.6	7.7	2.0	1280	68	82	6	1410
WE4-355M1-8	132	261	248	239	745	93.8	94.9	94.9	0.72	0.78	0.81	1.6	7.7	2.0	1820	75	90	10	1692
WE4-355M2-8	160	312	296	285	745	94.1	95.1	95.1	0.74	0.80	0.82	1.6	7.7	2.0	1960	75	90	13	2051
WE4-355L-8	200	388	369	356	745	94.3	95.4	95.4	0.74	0.80	0.82	1.6	7.8	2.0	2105	75	90	13	2564

Aluminium motor-3000/1500/1000 r/min (2/4/6 pole) IE4

Model	Power	Rated Current (A)			Speed	Efficiency (%)			Power Factor			Locked Rotor Torque	Locked Rotor Current	Maximum Torque	Weight	Noise		Moment of Inertia	Torque
	kW	I _n 380V	I _n 400V	I _n 415V	r/min	50%	75%	100%	50%	75%	100%					kg	L _{PA} dB(A)		
WE4-63M1-2	0.18	0.50	0.48	0.46	2770	70.5	71.2	70.8	0.62	0.72	0.77	2.2	7.1	2.3	5.5	49	61	0.00067	0.62
WE4-63M2-2	0.25	0.66	0.62	0.60	2775	74.0	74.6	74.3	0.63	0.74	0.78	2.2	7.1	2.3	6.5	49	61	0.00082	0.86
WE4-71M1-2	0.37	0.90	0.85	0.82	2830	77.9	78.5	78.1	0.66	0.77	0.80	2.2	7.1	2.3	8.5	52	64	0.00049	1.25
WE4-71M2-2	0.55	1.27	1.20	1.16	2835	81.3	81.8	81.5	0.67	0.78	0.81	2.2	7.1	2.3	9.5	52	64	0.00063	1.85
WE4-80M1-2	0.75	1.64	1.56	1.51	2875	83.2	83.3	83.5	0.74	0.80	0.83	2.2	8.5	2.3	13	50	62	0.001	2.49
WE4-80M2-2	1.1	2.36	2.25	2.16	2885	84.9	85.5	85.2	0.74	0.80	0.83	2.2	8.5	2.3	15	50	62	0.0014	3.64
WE4-90S-2	1.5	3.10	2.94	2.84	2890	86.2	87.1	86.5	0.75	0.82	0.85	2.2	9.0	2.3	19	55	67	0.0015	4.96
WE4-90L-2	2.2	4.42	4.20	4.04	2895	87.7	88.4	88.0	0.76	0.83	0.86	2.2	9.0	2.3	22	55	67	0.0017	7.3
WE4-100L-2	3	5.9	5.6	5.4	2900	88.8	89.7	89.1	0.79	0.84	0.87	2.2	9.5	2.3	30	62	74	0.0055	9.9
WE4-112M-2	4	7.7	7.3	7.0	2915	89.7	90.6	90.0	0.79	0.86	0.88	2.2	9.5	2.3	43	65	77	0.0075	13.1
WE4-132S1-2	5.5	10.4	9.9	9.6	2925	90.6	91.2	90.9	0.79	0.86	0.88	2.0	9.5	2.3	62	67	79	0.015	18
WE4-132S2-2	7.5	14.0	13.3	12.8	2925	91.4	92.3	91.7	0.80	0.86	0.89	2.0	9.5	2.3	67	67	79	0.019	24.5
WE4-160M1-2	11	20.3	19.3	18.6	2940	92.3	92.9	92.6	0.79	0.86	0.89	2.0	9.5	2.3	104	68	81	0.05	35.7
WE4-160M2-2	15	27.4	26.1	25.1	2940	92.9	93.5	93.3	0.79	0.86	0.89	2.0	9.5	2.3	114	68	81	0.059	48.7
WE4-160L-2	18.5	33.7	32.0	30.9	2940	93.4	94.1	93.7	0.81	0.87	0.89	2.0	9.5	2.3	131	68	81	0.069	60
WE4-63M1-4	0.12	0.37	0.35	0.34	1360	69.1	71.2	69.8	0.50	0.63	0.70	2.1	7.5	2.3	6.5	40	52	0.00054	0.84
WE4-63M2-4	0.18	0.52	0.50	0.48	1360	74.1	75.0	74.7	0.50	0.63	0.70	2.1	7.5	2.3	7.5	40	52	0.00068	1.26
WE4-71M1-4	0.25	0.68	0.64	0.62	1400	76.4	78.1	77.9	0.53	0.65	0.72	2.1	7.5	2.3	9.5	43	55	0.0012	1.71
WE4-71M2-4	0.37	0.96	0.91	0.88	1400	80.0	81.4	81.1	0.53	0.65	0.72	2.1	7.5	2.3	11	43	55	0.0015	2.52
WE4-80M1-4	0.55	1.35	1.28	1.23	1425	82.8	84.2	83.9	0.55	0.67	0.74	2.4	9.8	2.2	15	44	56	0.002	3.69
WE4-80M2-4	0.75	1.80	1.71	1.65	1425	84.5	86.1	85.7	0.55	0.67	0.74	2.3	8.5	2.3	18	44	56	0.0026	5.0
WE4-90S-4	1.1	2.56	2.43	2.34	1430	86.5	87.6	87.2	0.56	0.69	0.75	2.3	8.5	2.3	20	47	59	0.0037	7.3
WE4-90L-4	1.5	3.31	3.15	3.03	1430	87.5	88.5	88.2	0.60	0.72	0.78	2.3	9.0	2.3	25	47	59	0.0047	10.0
WE4-100L1-4	2.2	4.73	4.49	4.33	1435	89.2	89.7	89.5	0.62	0.73	0.79	2.3	9.0	2.3	29	52	64	0.011	14.6
WE4-100L2-4	3	6.3	6	5.8	1440	90.1	90.7	90.4	0.63	0.74	0.80	2.3	9.5	2.3	33	52	64	0.015	19.9
WE4-112M-4	4	8.3	7.9	7.6	1450	90.8	91.4	91.1	0.67	0.75	0.80	2.3	9.5	2.3	47	53	65	0.022	26.3
WE4-132S-4	5.5	11.4	10.8	10.4	1460	91.6	92.1	91.9	0.67	0.77	0.80	2.0	9.5	2.3	61	59	71	0.035	36.0
WE4-132M-4	7.5	15.2	14.4	13.9	1460	92.3	92.9	92.6	0.69	0.79	0.81	2.0	9.5	2.3	71	59	71	0.04	49.1
WE4-160M-4	11	21.6	20.5	19.8	1470	93.0	93.5	93.3	0.71	0.81	0.83	2.0	9.5	2.3	117	60	73	0.098	71
WE4-160L-4	15	28.9	27.4	26.5	1470	93.6	94.2	93.9	0.73	0.81	0.84	2.0	9.5	2.3	133	60	73	0.12	97
WE4-71M1-6	0.18	0.63	0.60	0.58	900	68.5	70.5	70.1	0.42	0.52	0.62	1.9	7.5	2.0	8.5	40	52	0.0011	1.91
WE4-71M2-6	0.25	0.80	0.76	0.73	900	72.9	74.6	74.1	0.44	0.55	0.64	1.9	7.5	2.0	10	40	52	0.0015	2.65
WE4-80M1-6	0.37	1.06	1.01	0.97	930	77.1	78.8	78.0	0.49	0.61	0.68	2.0	9.7	2.1	15	42	54	0.0023	3.8
WE4-80M2-6	0.55	1.48	1.40	1.35	930	80.3	81.7	80.9	0.51	0.63	0.70	2.0	9.0	2.1	18	42	54	0.0036	5.6
WE4-90S-6	0.75	1.97	1.87	1.80	940	82.4	83.5	82.7	0.51	0.63	0.70	2.1	7.5	2.1	19	45	57	0.0061	7.6
WE4-90L-6	1.1	2.83	2.68	2.59	945	84.1	85.3	84.5	0.52	0.64	0.70	2.1	7.5	2.1	25	45	57	0.0079	11.1
WE4-100L-6	1.5	3.74	3.55	3.42	950	84.9	86.7	85.9	0.56	0.66	0.71	2.1	7.5	2.1	31	49	61	0.014	15.1
WE4-112M-6	2.2	5.4	5.1	4.93	950	86.7	88.2	87.4	0.56	0.66	0.71	2.1	7.5	2.1	44	53	65	0.023	22.1
WE4-132S-6	3	7.2	6.9	6.6	960	88.2	88.9	88.6	0.57	0.66	0.71	2.0	7.5	2.1	61	57	69	0.029	29.8
WE4-132M1-6	4	9.4	9.0	8.6	960	88.9	89.8	89.5	0.59	0.67	0.72	2.0	8.0	2.1	67	57	69	0.038	39.8
WE4-132M2-6	5.5	12.8	12.2	11.7	965	89.7	90.8	90.5	0.59	0.67	0.72	2.0	8.0	2.1	71	57	69	0.054	54
WE4-160M-6	7.5	16.4	15.6	15.0	970	90.8	91.6	91.3	0.61	0.72	0.76	2.0	8.0	2.1	115	60	73	0.13	74
WE4-160L-6	11	23.5	22.3	21.5	970	91.7	92.4	92.3	0.62	0.73	0.77	2.0	8.5	2.1	132	60	73	0.19	108

IE3 Performance data

Cast iron motor-3000 r/min (2 pole) IE3

Model	Power	Rated Current (A)			Speed	Efficiency (%)			Power Factor			Locked Rotor Torque Rated Torque	Locked Rotor Current Rated Current	Maximum Torque Rated Torque	Weight	Noise		Moment of Inertia kg·m ²	Torque N.m
	kW	I _N 380V	I _N 400V	I _N 415V	r/min	50%	75%	100%	50%	75%	100%				kg	L _{PA} dB(A)	L _{WA} dB(A)		
WE3-80M1-2	0.75	1.72	1.64	1.58	2860	79.3	81.1	80.7	0.73	0.79	0.82	2.3	7.0	2.3	14	50	62	0.00099	2.5
WE3-80M2-2	1.1	2.43	2.31	2.23	2880	79.6	82.5	82.7	0.73	0.76	0.83	2.2	7.3	2.3	15	50	62	0.0013	3.65
WE3-90S-2	1.5	3.22	3.06	2.95	2885	84.1	84.9	84.2	0.74	0.81	0.84	2.2	7.6	2.3	23	55	67	0.0014	4.97
WE3-90L-2	2.2	4.58	4.35	4.19	2870	85.8	86.5	85.9	0.74	0.82	0.85	2.2	7.6	2.3	26	55	67	0.0016	7.3
WE3-100L-2	3	6	5.7	5.5	2900	86.2	87.4	87.1	0.79	0.84	0.87	2.2	7.8	2.3	37	62	74	0.0053	9.9
WE3-112M-2	4	7.8	7.4	7.2	2900	88.7	89.2	88.1	0.78	0.85	0.88	2.2	8.3	2.3	41	65	77	0.0069	13.2
WE3-132S1-2	5.5	10.6	10.1	9.7	2920	88.9	89.6	89.2	0.78	0.85	0.88	2.0	8.3	2.3	59	67	79	0.014	18
WE3-132S2-2	7.5	14.4	13.7	13.2	2905	89.9	90.6	90.1	0.79	0.85	0.88	2.0	7.9	2.3	67	67	79	0.018	24.7
WE3-160M1-2	11	20.6	19.6	18.9	2940	89.9	91.1	91.2	0.78	0.86	0.89	2.0	8.1	2.3	117	68	81	0.046	35.7
WE3-160M2-2	15	27.9	26.5	25.5	2930	91.3	92.1	91.9	0.79	0.86	0.89	2.0	8.1	2.3	122	68	81	0.053	48.9
WE3-160L-2	18.5	34.2	32.5	31.3	2930	92.2	92.7	92.4	0.81	0.87	0.89	2.0	8.2	2.3	134	68	81	0.063	60
WE3-180M-2	22	40.5	38.5	37.1	2945	92.1	92.9	92.7	0.81	0.87	0.89	2.0	8.2	2.3	168	70	83	0.092	71
WE3-200L1-2	30	55	52	50	2970	91.3	92.9	93.3	0.80	0.87	0.89	2.0	7.6	2.3	253	71	84	0.18	96
WE3-200L2-2	37	67	64	62	2970	91.8	93.3	93.7	0.78	0.86	0.89	2.0	7.6	2.3	271	71	84	0.22	119
WE3-225M-2	45	81	77	74	2970	92.4	94.0	94.0	0.83	0.88	0.90	2.0	7.7	2.3	323	73	86	0.36	145
WE3-250M-2	55	98	94	90	2970	93.0	94.3	94.3	0.78	0.86	0.90	2.0	7.7	2.3	417	75	89	0.45	177
WE3-280S-2	75	134	127	122	2980	93.5	94.7	94.7	0.83	0.87	0.90	1.8	7.1	2.3	530	77	91	0.82	240
WE3-280M-2	90	160	152	146	2980	93.3	95.0	95.0	0.80	0.87	0.90	1.8	7.1	2.3	665	77	91	1	288
WE3-315S-2	110	195	185	179	2985	93.8	95.2	95.2	0.86	0.89	0.90	1.8	7.1	2.3	944	78	92	1.4	352
WE3-315M-2	132	234	222	214	2985	94.0	95.4	95.4	0.84	0.87	0.90	1.8	7.1	2.3	1054	78	92	1.5	422
WE3-315L1-2	160	279	265	256	2985	94.7	95.6	95.6	0.85	0.88	0.91	1.8	7.2	2.3	1149	78	92	2	512
WE3-315L2-2	185	323	307	296	2985	94.6	95.7	95.7	0.86	0.88	0.91	1.8	7.2	2.2	1209	78	92	2.2	592
WE3-315L3-2	200	349	331	319	2985	95.2	95.8	95.8	0.87	0.89	0.91	1.8	7.2	2.2	1249	78	92	2.4	640
WE3-355M1-2	220	383	364	351	2990	95.5	95.8	95.8	0.87	0.89	0.91	1.6	7.2	2.2	1699	85	100	4	703
WE3-355M2-2	250	436	414	399	2990	95.4	95.8	95.8	0.88	0.89	0.91	1.6	7.2	2.2	1716	85	100	4.7	798
WE3-355L1-2	280	488	464	447	2990	94.8	95.8	95.8	0.88	0.89	0.91	1.6	7.2	2.2	2068	85	100	4.3	894
WE3-355L2-2	315	549	522	503	2990	95.3	95.8	95.8	0.88	0.89	0.91	1.6	7.2	2.2	2091	85	100	5.7	1006
WE3-3551-2	355	619	588	567	2990	95.3	95.8	95.8	0.88	0.89	0.91	1.6	7.2	2.2	2406	89	104	6.5	1134
WE3-3552-2	375	654	621	598	2990	95.3	95.8	95.8	0.88	0.89	0.91	1.6	7.2	2.2	2419	89	104	6.5	1198

▼ Cast iron motor-1500 r/min (4 pole) IE3

Model	Power	Rated Current (A)			Speed	Efficiency (%)			Power Factor			Locked Rotor Torque Rated Torque	Locked Rotor Current Rated Current	Maximum Torque Rated Torque	Weight	Noise		Moment of Inertia		Torque
	kW	I _n 380V	I _n 400V	I _n 415V	r/min	50%	75%	100%	50%	75%	100%				kg	LPA dB(A)	LWA dB(A)	kg·m ²	N·m	
WE3-80M1-4	0.55	1.38	1.31	1.26	1425	77.9	80.8	80.8	0.57	0.68	0.75	2.3	6.6	2.3	18	44	56	0.0018	3.69	
WE3-80M2-4	0.75	1.84	1.75	1.69	1425	79.6	82.4	82.5	0.57	0.69	0.75	2.3	6.6	2.3	19	44	56	0.0023	5	
WE3-90S-4	1.1	2.61	2.48	2.39	1430	83.2	84.6	84.1	0.56	0.69	0.76	2.3	6.8	2.3	23	47	59	0.0034	7.3	
WE3-90L-4	1.5	3.47	3.3	3.18	1425	84.7	85.8	85.3	0.58	0.70	0.77	2.3	7.0	2.3	26	47	59	0.0043	10.1	
WE3-100L1-4	2.2	4.76	4.52	4.36	1445	84.8	86.8	86.7	0.64	0.75	0.81	2.3	7.6	2.3	38	52	64	0.01	14.5	
WE3-100L2-4	3	6.3	6	5.8	1420	85.7	87.7	87.7	0.65	0.76	0.82	2.3	7.6	2.3	43	52	64	0.014	20.2	
WE3-112M-4	4	8.4	7.9	7.7	1450	88.5	89.2	88.6	0.69	0.78	0.82	2.2	7.8	2.3	48	53	65	0.02	26.3	
WE3-132S-4	5.5	11.2	10.7	10.3	1460	89.3	90.0	89.6	0.67	0.77	0.83	2.0	7.9	2.3	69	59	71	0.032	36	
WE3-132M-4	7.5	15	14.3	13.7	1445	90.9	91.2	90.4	0.70	0.80	0.84	2.0	7.5	2.3	77	59	71	0.036	49.6	
WE3-160M-4	11	21.5	20.4	19.7	1470	90.7	91.6	91.4	0.70	0.80	0.85	2.2	7.7	2.3	120	60	73	0.089	71	
WE3-160L-4	15	28.8	27.3	26.3	1470	92.0	92.5	92.1	0.74	0.82	0.86	2.2	7.8	2.3	133	60	73	0.11	97	
WE3-180M-4	18.5	35.3	33.5	32.3	1475	92.0	92.8	92.6	0.71	0.81	0.86	2.0	7.8	2.3	172	63	76	0.17	120	
WE3-180L-4	22	41.8	39.7	38.3	1475	92.2	93.0	93.0	0.72	0.82	0.86	2.0	7.8	2.3	195	63	76	0.2	142	
WE3-200L-4	30	57	54	52	1475	92.7	93.6	93.6	0.76	0.83	0.86	2.0	7.3	2.3	268	63	76	0.42	194	
WE3-225S-4	37	70	66	64	1480	92.4	93.9	93.9	0.74	0.82	0.86	2.0	7.4	2.3	299	65	78	0.46	239	
WE3-225M-4	45	84	80	77	1480	92.8	94.2	94.2	0.75	0.82	0.86	2.0	7.4	2.3	337	65	78	0.53	290	
WE3-250M-4	55	103	98	94	1480	93.0	94.6	94.6	0.77	0.82	0.86	2.2	7.4	2.3	432	65	79	0.84	355	
WE3-280S-4	75	136	129	125	1485	93.3	95.0	95.0	0.78	0.85	0.88	2.0	6.9	2.3	576	66	80	1.5	482	
WE3-280M-4	90	163	155	149	1485	93.6	95.2	95.2	0.76	0.83	0.88	2.0	6.9	2.3	661	66	80	1.8	579	
WE3-315S-4	110	197	187	180	1490	93.6	95.4	95.4	0.82	0.86	0.89	2.0	7.0	2.2	982	74	88	2.9	705	
WE3-315M-4	132	236	224	216	1490	94.8	95.6	95.6	0.82	0.87	0.89	2.0	7.0	2.2	1015	74	88	3.3	846	
WE3-315L1-4	160	285	271	261	1490	95.2	95.8	95.8	0.84	0.86	0.89	2.0	7.1	2.2	1050	74	88	3.9	1026	
WE3-315L2-4	185	329	313	302	1490	95.3	95.3	95.9	0.83	0.86	0.89	2.0	7.1	2.2	1087	74	88	5.1	1186	
WE3-315L3-4	200	352	334	322	1490	95.8	96.0	96.0	0.86	0.88	0.90	2.0	7.1	2.2	1111	74	88	5.1	1282	
WE3-355M1-4	220	391	372	358	1495	95.8	96.0	96.0	0.84	0.87	0.89	2.0	7.1	2.2	1527	80	95	8.9	1405	
WE3-355M2-4	250	440	418	403	1495	95.6	96.0	96.0	0.85	0.88	0.90	2.0	7.1	2.2	1547	80	95	8.2	1597	
WE3-355L1-4	280	492	468	451	1495	95.4	96.0	96.0	0.85	0.88	0.90	2.0	7.1	2.2	1670	80	95	11	1789	
WE3-355L2-4	315	554	526	507	1495	94.9	96.0	96.0	0.86	0.87	0.90	2.0	7.1	2.2	1827	80	95	9.2	2012	
WE3-3551-4	355	638	607	585	1495	94.9	96.0	96.0	0.84	0.85	0.88	1.7	7.0	2.2	2012	87	102	10	2268	
WE3-3552-4	375	674	641	618	1495	94.9	96.0	96.0	0.84	0.85	0.88	1.7	7.0	2.2	2307	87	102	12	2395	

Cast iron motor-1000 r/min (6 pole) IE3

Model	Power	Rated Current (A)			Speed	Efficiency (%)			Power Factor			Locked Rotor Torque Rated Torque	Locked Rotor Current Rated Current	Maximum Torque Rated Torque	Weight kg	Noise		Moment of Inertia kg·m ²	Torque N.m
	kW	I _N 380V	I _N 400V	I _N 415V	r/min	50%	75%	100%	50%	75%	100%					L _{PA} dB(A)	L _{WA} dB(A)		
WE3-80M1-6	0.37	1.09	1.04	1	925	72.7	74.8	73.5	0.50	0.62	0.70	2.0	6.0	2.1	17	42	54	0.0021	3.82
WE3-80M2-6	0.55	1.5	1.43	1.38	925	77.0	78.6	77.2	0.53	0.65	0.72	2.0	6.0	2.1	19	42	54	0.0033	5.7
WE3-90S-6	0.75	2.03	1.93	1.86	940	77.5	79.3	78.9	0.51	0.64	0.71	2.0	6.0	2.1	24	45	57	0.0055	7.6
WE3-90L-6	1.1	2.83	2.69	2.59	945	81.1	82.1	81.0	0.55	0.67	0.73	2.0	6.0	2.1	26	45	57	0.0072	11.1
WE3-100L-6	1.5	3.78	3.59	3.47	960	81.5	83.2	82.5	0.57	0.68	0.73	2.0	6.5	2.1	39	49	61	0.013	14.9
WE3-112M-6	2.2	5.4	5.1	4.91	950	82.6	84.5	84.3	0.56	0.67	0.74	2.0	6.6	2.1	45	53	65	0.021	22.1
WE3-132S-6	3	7.2	6.8	6.6	960	82.4	86.4	85.6	0.57	0.68	0.74	2.0	6.8	2.1	56	57	69	0.027	29.8
WE3-132M1-6	4	9.5	9	8.7	960	86.4	87.3	86.8	0.57	0.68	0.74	2.0	6.8	2.1	69	57	69	0.034	39.8
WE3-132M2-6	5.5	12.7	12	11.6	965	87.3	88.2	88.0	0.58	0.69	0.75	2.0	7.0	2.1	81	57	69	0.049	54
WE3-160M-6	7.5	16.2	15.4	14.8	970	88.0	89.2	89.1	0.63	0.74	0.79	2.0	7.0	2.1	117	60	73	0.12	74
WE3-160L-6	11	23.1	22	21.2	970	89.3	90.4	90.3	0.64	0.75	0.80	2.0	7.2	2.1	143	60	73	0.17	108
WE3-180L-6	15	30.9	29.3	28.2	975	90.5	91.4	91.2	0.69	0.78	0.81	2.0	7.3	2.1	194	60	73	0.27	147
WE3-200L1-6	18.5	37.8	35.9	34.7	980	90.5	91.7	91.7	0.69	0.77	0.81	2.0	7.3	2.1	235	60	73	0.4	180
WE3-200L2-6	22	44.8	42.5	41	980	91.2	92.2	92.2	0.68	0.77	0.81	2.0	7.4	2.1	255	60	73	0.47	214
WE3-225M-6	30	59	56	54	980	91.8	92.9	92.9	0.78	0.81	0.83	2.0	6.9	2.1	339	61	74	0.96	292
WE3-250M-6	37	72	68	66	985	92.6	93.3	93.3	0.72	0.80	0.84	2.0	7.1	2.1	437	62	76	1.3	359
WE3-280S-6	45	86	82	79	985	92.0	93.7	93.7	0.78	0.82	0.85	2.0	7.3	2.0	511	64	78	2.6	436
WE3-280M-6	55	103	98	95	985	92.6	94.1	94.1	0.76	0.83	0.86	2.0	7.3	2.0	656	64	78	3.3	533
WE3-315S-6	75	143	136	131	990	94.3	94.6	94.6	0.77	0.80	0.84	2.0	6.6	2.0	972	69	83	3.6	723
WE3-315M-6	90	170	161	155	990	94.2	94.9	94.9	0.73	0.80	0.85	2.0	6.7	2.0	1095	69	83	4.2	868
WE3-315L1-6	110	207	196	189	990	94.8	95.1	95.1	0.76	0.81	0.85	2.0	6.7	2.0	1190	69	83	5.2	1061
WE3-315L2-6	132	244	232	224	990	94.9	95.4	95.4	0.77	0.83	0.86	2.0	6.8	2.0	1265	69	83	6.2	1273
WE3-355M1-6	160	296	281	271	995	95.3	95.6	95.6	0.85	0.84	0.86	1.8	6.8	2.0	1497	70	85	9.8	1536
WE3-355M2-6	200	365	346	334	995	94.6	95.8	95.8	0.81	0.84	0.87	1.8	6.8	2.0	1674	70	85	12	1920
WE3-355L1-6	220	406	385	371	995	94.6	95.8	95.8	0.82	0.84	0.86	1.8	6.8	2.0	2002	70	85	13	2112
WE3-355L2-6	250	461	438	422	995	95.2	95.8	95.8	0.82	0.85	0.86	1.8	6.8	2.0	2022	76	85	14	2399
WE3-3551-6	280	516	491	473	995	95.2	95.8	95.8	0.82	0.85	0.86	1.8	6.8	2.0	2047	76	91	15	2687
WE3-3552-6	315	581	552	532	995	95.2	95.8	95.8	0.82	0.85	0.86	1.8	6.8	2.0	2112	76	91	16	3023

▼ Cast iron motor-750 r/min (8 pole) IE3

Model	Power	Rated Current (A)			Speed	Efficiency (%)			Power Factor			Locked Rotor Torque Rated Torque	Locked Rotor Current Rated Current	Maximum Torque Rated Torque	Weight	Noise		Moment of Inertia	Torque
	kW	I _n 380V	I _n 400V	I _n 415V	r/min	50%	75%	100%	50%	75%	100%				kg	LPA dB(A)	LWA dB(A)	kg·m ²	N.m
WE3-80M1-8	0.18	0.76	0.73	0.7	695	54.6	59.1	58.7	0.40	0.50	0.61	1.8	3.3	1.9	17	40	52	0.0033	2.47
WE3-80M2-8	0.25	0.97	0.92	0.89	695	59.8	64.2	64.1	0.39	0.50	0.61	1.8	3.3	1.9	19	40	52	0.004	3.44
WE3-90S-8	0.37	1.33	1.26	1.22	700	67.1	71.1	69.3	0.42	0.54	0.61	1.8	4.0	1.9	22	44	56	0.0049	5
WE3-90L-8	0.55	1.88	1.78	1.72	700	69.7	73.3	73.0	0.43	0.55	0.61	1.8	4.0	2.0	25	44	56	0.0061	7.5
WE3-100L1-8	0.75	2.27	2.15	2.08	710	74.3	76.0	75.0	0.53	0.64	0.67	1.8	4.0	2.0	34	47	59	0.013	10.1
WE3-100L2-8	1.1	3.12	2.96	2.85	710	77.3	78.2	77.7	0.54	0.67	0.69	1.8	5.0	2.0	38	47	59	0.016	14.8
WE3-112M-8	1.5	4.14	3.94	3.79	710	79.2	81.3	79.7	0.53	0.65	0.69	1.8	5.0	2.0	41	49	61	0.023	20.2
WE3-132S-8	2.2	5.7	5.5	5.3	715	81.2	82.2	81.9	0.52	0.65	0.71	1.8	6.0	2.0	58	52	64	0.03	29.4
WE3-132M-8	3	7.5	7.1	6.8	715	83.1	84.0	83.5	0.50	0.63	0.73	1.8	6.0	2.0	73	52	64	0.04	40.1
WE3-160M1-8	4	9.8	9.3	9	730	85.2	86.3	84.8	0.52	0.65	0.73	1.9	6.0	2.0	102	55	68	0.092	52
WE3-160M2-8	5.5	13.1	12.4	12	725	86.4	86.5	86.2	0.55	0.69	0.74	2.0	6.0	2.0	109	55	68	0.11	72
WE3-160L-8	7.5	17.4	16.5	15.9	730	87.1	88.0	87.3	0.54	0.67	0.75	2.0	6.0	2.0	130	55	68	0.14	98
WE3-180L-8	11	24.8	23.6	22.7	730	88.6	89.6	88.6	0.56	0.68	0.76	2.0	6.6	2.0	193	57	70	0.28	144
WE3-200L-8	15	33.5	31.8	30.6	735	89.4	90.0	89.6	0.58	0.70	0.76	2.0	6.6	2.0	259	60	73	0.56	195
WE3-225S-8	18.5	41	39	37.6	735	90.0	90.9	90.1	0.61	0.72	0.76	1.9	6.6	2.0	287	60	73	0.86	240
WE3-225M-8	22	47.3	44.9	43.3	735	90.4	91.2	90.6	0.62	0.73	0.78	1.9	6.6	2.0	330	60	73	0.97	286
WE3-250M-8	30	63	60	58	740	91.2	91.6	91.3	0.65	0.76	0.79	1.9	6.6	2.0	452	61	75	1.5	387
WE3-280S-8	37	78	74	71	740	91.8	92.2	91.8	0.70	0.80	0.79	1.9	6.6	2.0	484	62	76	2.8	478
WE3-280M-8	45	94	89	86	740	92.1	92.5	92.2	0.70	0.80	0.79	1.9	6.6	2.0	623	62	76	3.3	581
WE3-315S-8	55	112	106	102	740	92.1	92.7	92.5	0.66	0.77	0.81	1.8	6.6	2.0	927	68	82	5.2	710
WE3-315M-8	75	151	144	138	740	92.7	93.4	93.1	0.68	0.78	0.81	1.8	6.6	2.0	1085	68	82	6.4	968
WE3-315L1-8	90	179	170	163	740	92.9	93.6	93.4	0.68	0.78	0.82	1.8	6.6	2.0	1213	68	82	7.3	1161
WE3-315L2-8	110	218	207	199	740	93.1	93.9	93.7	0.70	0.79	0.82	1.8	6.4	2.0	1288	68	82	8.4	1420
WE3-355M1-8	132	260	247	238	745	93.3	94.0	94.0	0.71	0.79	0.82	1.8	6.4	2.0	1523	75	90	13	1692
WE3-355M2-8	160	314	299	288	745	93.7	94.3	94.3	0.73	0.80	0.82	1.8	6.4	2.0	1640	75	90	15	2051
WE3-355L-8	200	387	368	354	745	93.9	94.6	94.6	0.72	0.80	0.83	1.8	6.4	2.0	1993	75	90	17	2564

Aluminium motor-3000/1500/1000 r/min (2/4/6 pole) IE3

Model	Power	Rated Current (A)			Speed	Efficiency (%)			Power Factor			Locked Rotor Torque Rated Torque	Locked Rotor Current Rated Current	Maximum Torque Rated Torque	Weight kg	Noise		Moment of inertia kg·m ²	Torque N·m
	kW	I _N 380V	I _N 400V	I _N 415V	r/min	50%	75%	100%	50%	75%	100%					L _{PA} dB(A)	L _{WA} dB(A)		
WE3-63M1-3	0.18	0.54	0.51	0.49	2765	58.5	67.2	65.9	0.62	0.72	0.77	2.2	7.1	2.3	5.0	49	61	0.00063	0.62
WE3-63M2-2	0.25	0.70	0.66	0.64	2770	60.3	71.1	69.7	0.63	0.74	0.78	2.2	7.1	2.3	5.8	49	61	0.00080	0.86
WE3-71M1-2	0.37	0.94	0.89	0.86	2815	71.2	73.2	73.8	0.63	0.73	0.81	2.3	7.0	2.2	6.6	52	64	0.00053	1.26
WE3-71M2-2	0.55	1.31	1.24	1.20	2835	75.3	77.6	77.8	0.64	0.74	0.82	2.3	7.0	2.3	7.6	52	64	0.00066	1.85
WE3-80M1-2	0.75	1.72	1.64	1.58	2860	79.3	81.1	80.7	0.73	0.79	0.82	2.3	7.0	2.3	11	50	62	0.00099	2.5
WE3-80M2-2	1.1	2.43	2.31	2.23	2880	79.6	82.5	82.7	0.73	0.76	0.83	2.2	7.3	2.3	12.5	50	62	0.0013	3.65
WE3-90S-2	1.5	3.22	3.06	2.95	2885	84.1	84.9	84.2	0.74	0.81	0.84	2.2	7.6	2.3	16	55	67	0.0014	4.97
WE3-90L-2	2.2	4.58	4.35	4.19	2870	85.8	86.5	85.9	0.74	0.82	0.85	2.2	7.6	2.3	19	55	67	0.0016	7.3
WE3-100L-2	3	6	5.7	5.5	2900	86.2	87.4	87.1	0.79	0.84	0.87	2.2	7.8	2.3	26	62	74	0.0053	9.9
WE3-112M-2	4	7.8	7.4	7.2	2900	88.7	89.2	88.1	0.78	0.85	0.88	2.2	8.3	2.3	33	65	77	0.0069	13.2
WE3-132S1-2	5.5	10.6	10.1	9.7	2920	88.9	89.6	89.2	0.78	0.85	0.88	2.0	8.3	2.3	45	67	79	0.014	18
WE3-132S2-2	7.5	14.4	13.7	13.2	2905	89.9	90.6	90.1	0.79	0.85	0.88	2.0	7.9	2.3	50	67	79	0.018	24.7
WE3-160M1-2	11	20.6	19.6	18.9	2940	89.9	91.1	91.2	0.78	0.86	0.89	2.0	8.1	2.3	82	68	81	0.046	35.7
WE3-160M2-2	15	27.9	26.5	25.5	2930	91.3	92.1	91.9	0.79	0.86	0.89	2.0	8.1	2.3	90	68	81	0.053	48.9
WE3-160L-2	18.5	34.2	32.5	31.3	2930	92.2	92.7	92.4	0.81	0.87	0.89	2.0	8.2	2.3	104	68	81	0.063	60
WE3-63M1-4	0.12	0.40	0.38	0.37	1355	64.1	66.2	64.8	0.50	0.63	0.70	2.1	7.5	2.3	6.0	40	52	0.00051	0.84
WE3-63M2-4	0.18	0.56	0.53	0.51	1355	69.1	71.0	69.9	0.50	0.63	0.70	2.1	7.5	2.3	7.0	40	52	0.00065	1.26
WE3-71M1-4	0.25	0.70	0.66	0.64	1390	70.2	73.1	73.5	0.52	0.64	0.74	2.1	6.6	2.2	8.3	43	55	0.0013	1.72
WE3-71M2-4	0.37	0.97	0.92	0.89	1390	74.1	76.8	77.3	0.53	0.65	0.75	2.1	6.6	2.2	9.0	43	55	0.0015	2.54
WE3-80M1-4	0.55	1.38	1.31	1.26	1425	77.9	80.8	80.8	0.57	0.68	0.75	2.3	6.6	2.3	11.5	44	56	0.0018	3.69
WE3-80M2-4	0.75	1.84	1.75	1.69	1425	79.6	82.4	82.5	0.57	0.69	0.75	2.3	6.6	2.3	12.5	44	56	0.0023	5
WE3-90S-4	1.1	2.61	2.48	2.39	1430	83.2	84.6	84.1	0.56	0.69	0.76	2.3	6.8	2.3	16	47	59	0.0034	7.4
WE3-90L-4	1.5	3.47	3.3	3.18	1425	84.7	85.8	85.3	0.58	0.70	0.77	2.3	7.0	2.3	19	47	59	0.0043	10.1
WE3-100L1-4	2.2	4.76	4.52	4.36	1445	84.8	86.8	86.7	0.64	0.75	0.81	2.3	7.6	2.3	26	52	64	0.01	14.5
WE3-100L2-4	3	6.3	6	5.8	1420	85.7	87.7	87.7	0.65	0.76	0.82	2.3	7.6	2.3	31	52	64	0.014	20.2
WE3-112M-4	4	8.4	7.9	7.7	1450	88.5	89.2	88.6	0.69	0.78	0.82	2.2	7.8	2.3	38	53	65	0.02	26.3
WE3-132S-4	5.5	11.2	10.7	10.3	1460	89.3	90.0	89.6	0.67	0.77	0.83	2.0	7.9	2.3	48	59	71	0.032	36
WE3-132M-4	7.5	15	14.3	13.7	1445	90.9	91.2	90.4	0.70	0.80	0.84	2.0	7.5	2.3	59	59	71	0.036	49.6
WE3-160M-4	11	21.5	20.4	19.7	1470	90.7	91.6	91.4	0.70	0.80	0.85	2.2	7.7	2.3	96	60	73	0.089	71
WE3-160L-4	15	28.8	27.3	26.3	1470	92.0	92.5	92.1	0.74	0.82	0.86	2.2	7.8	2.3	106	60	73	0.11	97
WE3-71M1-6	0.18	0.65	1.07	1.03	900	60.5	63.4	63.9	0.45	0.56	0.66	1.9	6.0	2.0	6.0	40	52	0.0013	1.91
WE3-71M2-6	0.25	0.81	1.34	1.29	900	65.6	68.1	68.6	0.45	0.58	0.68	1.9	6.0	2.0	7.5	40	52	0.0014	2.65
WE3-80M1-6	0.37	1.09	1.04	1.00	925	72.7	74.8	73.5	0.50	0.62	0.70	2.0	6.0	2.1	11	42	54	0.0021	3.82
WE3-80M2-6	0.55	1.50	1.43	1.38	925	77.0	78.6	77.2	0.53	0.65	0.72	2.0	6.0	2.1	12.5	42	54	0.0033	5.7
WE3-90S-6	0.75	2.03	1.93	1.86	940	77.5	79.3	78.9	0.51	0.64	0.71	2.0	6.0	2.1	16	45	57	0.0055	7.6
WE3-90L-6	1.1	2.83	2.69	2.59	945	81.1	82.1	81.0	0.55	0.67	0.73	2.0	6.0	2.1	19	45	57	0.0072	11.1
WE3-100L-6	1.5	3.78	3.59	3.47	960	81.5	83.2	82.5	0.57	0.68	0.73	2.0	6.5	2.1	28	49	61	0.013	14.9
WE3-112M-6	2.2	5.4	5.1	4.91	950	82.6	84.5	84.3	0.56	0.67	0.74	2.0	6.6	2.1	36	53	65	0.021	22.1
WE3-132S-6	3	7.2	6.8	6.6	960	82.4	86.4	85.6	0.57	0.68	0.74	2.0	6.8	2.1	42	57	69	0.027	29.8
WE3-132M1-6	4	9.5	9	8.7	960	86.4	87.3	86.8	0.57	0.68	0.74	2.0	6.8	2.1	49	57	69	0.034	39.8
WE3-132M2-6	5.5	12.7	12	11.6	965	87.3	88.2	88.0	0.58	0.69	0.75	2.0	7.0	2.1	64	57	69	0.049	54
WE3-160M-6	7.5	16.2	15.4	14.8	970	88.0	89.2	89.1	0.63	0.74	0.79	2.0	7.0	2.1	89	60	73	0.12	74
WE3-160L-6	11	23.1	22	21.2	970	89.3	90.4	90.3	0.64	0.75	0.80	2.0	7.2	2.1	109	60	73	0.17	108

Motor installation and dimensions B3

Foot (B3) mounted - frame sizes 63~ 355

IM B3
IM 1001
63~100

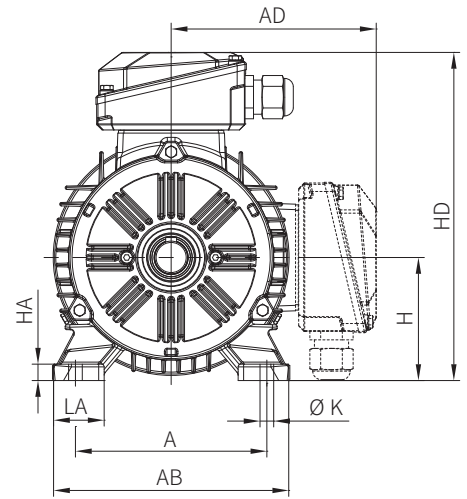
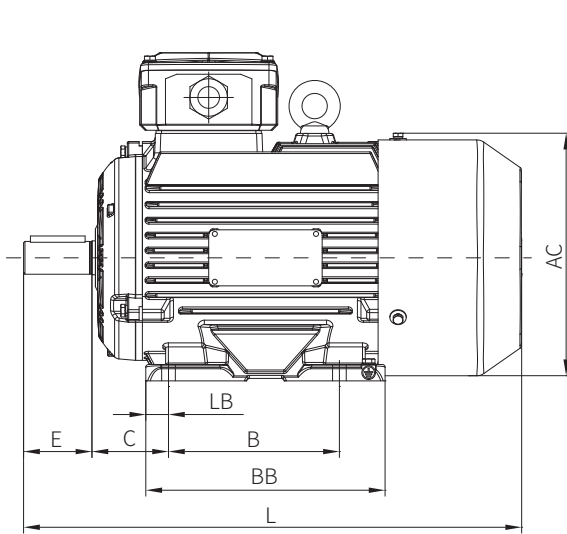

IM B3
IM 1001
112~200

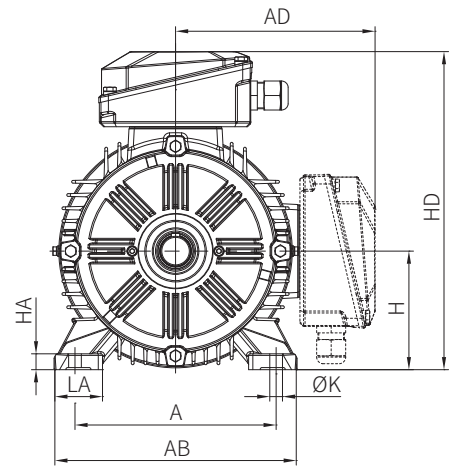
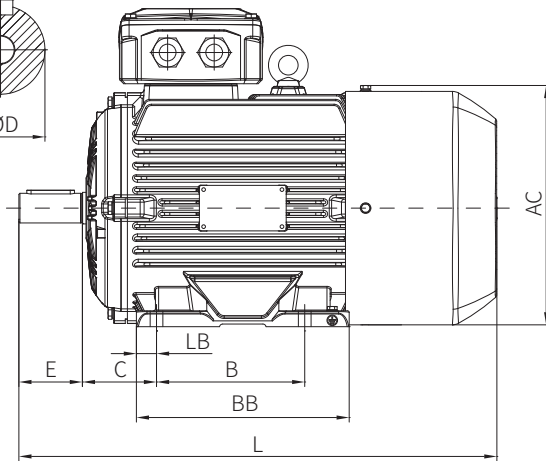
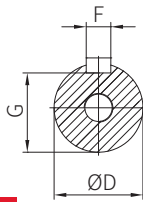

IM B3
IM 1001
225~355

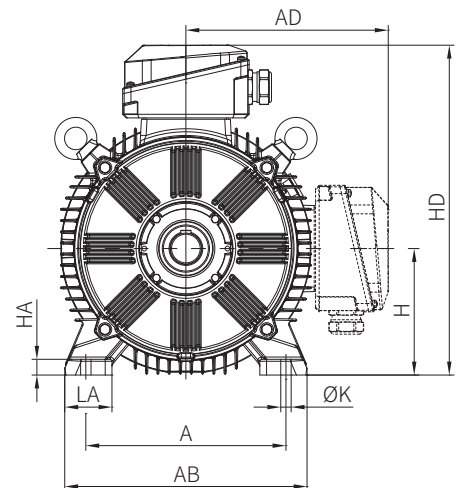
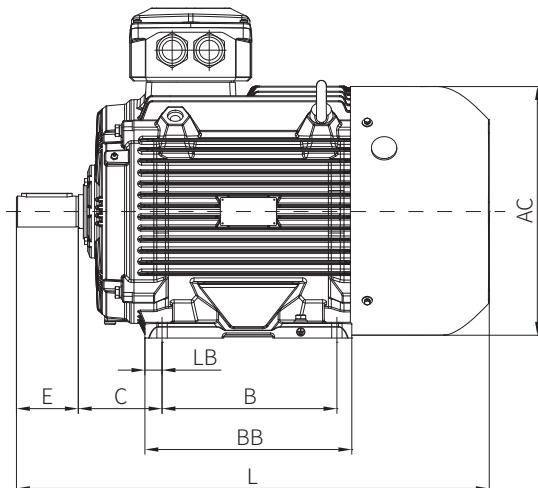

WE5 Foot (B3) mounted, cast iron motor

Frame	Poles	Mounting dimensions [mm]										Boundary dimension [mm]								
		A	A/2	B	C	D	E	F	G	H	K	LA	LB	AB	BB	HA	AC	AD	HD	L
80M	2-8	125	62.5	100	50	19	40	6	15.5	80	10	32	15	157	190	10	163	141	221	340
80M	2-8	125	62.5	100	50	19	40	6	15.5	80	10	32	15	157	190	10	163	141	221	340
90S	2-8	140	70	100	56	24	50	8	20	90	10	37	16.6	172	164	12	177	155	245	355
90L	2-8	140	70	125	56	24	50	8	20	90	10	37	16.6	172	190	12	177	155	245	395
100L	2-8	160	80	140	63	28	60	8	24	100	12	45	19	200	215.5	15	215	175	275	440
112M	2-8	190	95	140	70	28	60	8	24	112	12	45	28.5	228	220	15	215	193	305	450
132S	2-8	216	108	140	89	38	80	10	33	132	12	56.5	16.5	262	200	18	280	228	360	490
132M	2-8	216	108	178	89	38	80	10	33	132	12	56.5	16.5	262	258	18	280	228	360	545
160M	2-8	254	127	210	108	42	110	12	37	160	14.5	65	23	314	316	20	325	280	440	660
160L	2-8	254	127	254	108	42	110	12	37	160	14.5	65	23	314	386	20	325	280	440	730
180M	2-8	279	139.5	241	121	48	110	14	42.5	180	14.5	68	26.5	349	325	22	368	300	480	720
180L	2-8	279	139.5	279	121	48	110	14	42.5	180	14.5	68	26.5	349	360	22	368	300	480	760
200L	2-8	318	159	305	133	55	110	16	49	200	18.5	84	30	388	370	25	415	345	545	805
225S	4,8	356	178	286	149	60	140	18	53	225	18.5	84	30.5	431	370	28	460	375	600	845
225M	2	356	178	311	149	55	110	16	49	225	18.5	84	30.5	431	415	28	460	375	600	860
225M	4-8	356	178	311	149	60	140	18	53	225	18.5	84	30.5	431	415	28	460	375	600	890
250M	2	406	203	349	168	60	140	18	53	250	24	80	43	484	421	30	501	435	685	920
250M	4-8	406	203	349	168	65	140	18	58	250	24	80	43	484	421	30	501	435	685	920
280S	2	457	228.5	368	190	65	140	18	58	280	24	84	58.5	542	467	35	562	470	750	985
280S	4-8	457	228.5	368	190	75	140	20	67.5	280	24	84	58.5	542	467	35	562	470	750	985
280M	2	457	228.5	419	190	65	140	18	58	280	24	84	58.5	542	515	35	562	470	750	1035
280M	4-8	457	228.5	419	190	75	140	20	67.5	280	24	84	58.5	542	515	35	562	470	750	1035
315S	2	508	254	406	216	65	140	18	58	315	28	120	61	628	670	45	646	525	840	1285
315S	4-8	508	254	406	216	80	170	22	71	315	28	120	61	628	670	45	646	525	840	1315
315M	2	508	254	457	216	65	140	18	58	315	28	120	61	628	770	45	646	525	840	1385
315M	4-8	508	254	457	216	80	170	22	71	315	28	120	61	628	770	45	646	525	840	1415
315L	2	508	254	508	216	65	140	18	58	315	28	120	61	628	770	45	646	525	840	1385
315L	4-8	508	254	508	216	80	170	22	71	315	28	120	61	628	770	45	646	525	840	1415
355M	2	630	315	630	254	75	140	20	67.5	355	28	150	41	766	875	45	740	665	1020	1580
355M	4-8	630	315	630	254	95	170	25	86	355	28	150	41	766	875	45	740	665	1020	1610
355L	2	630	315	710	254	75	140	20	67.5	355	28	150	49	766	985	45	740	665	1020	1690
355L	4-8	630	315	710	254	95	170	25	86	355	28	150	49	766	985	45	740	665	1020	1720
3551	2	630	315	710	254	75	140	20	67.5	355	28	150	49	766	985	45	740	665	1020	1690
3552	4-8	630	315	710	254	95	170	25	86	355	28	150	49	766	985	45	740	665	1020	1720

WE4 Foot (B3) mounted, cast iron motor

Frame	Poles	Mounting dimensions (mm)									Boundary dimension (mm)								
		A	B	C	D	E	F	G	H	K	LA	LB	AB	BB	HA	AC	AD	HD	L
80M	2~8	125	100	50	19	40	6	15.5	80	10	32	15	157	146	10	163	136	221	320
90S	2~8	140	100	56	24	50	8	20	90	10	37	16.6	172	153	12	177	149	244	345
90L	2~8	140	125	56	24	50	8	20	90	10	37	16.6	172	175	12	177	149	244	370
100L	2~8	160	140	63	28	60	8	24	100	12	45	19	200	198	15	208	163	268	420
112M	2~8	190	140	70	28	60	8	24	112	12	45	19	228	201	15	226	189	305	465
132S	2~8	216	140	89	38	80	10	33	132	12	56.5	21.5	262	184	18	260	210	345	450
132M	4~8	216	178	89	38	80	10	33	132	12	56.5	21.5	262	222	18	260	210	345	490
160M	2~8	254	210	108	42	110	12	37	160	14.5	65	27	314	280	20	320	260	422	620
160L	2~8	254	254	108	42	110	12	37	160	14.5	65	27	314	324	20	320	260	422	665
180M	2,4	279	241	121	48	110	14	42.5	180	14.5	68	26.5	349	297	22	360	279	463	735
180L	4~8	279	279	121	48	110	14	42.5	180	14.5	68	26.5	349	335	22	360	279	463	770
200L	2~8	318	305	133	55	110	16	49	200	18.5	84	30	388	380	25	396	321	526	845
225S	4,8	356	286	149	60	140	18	53	225	18.5	84	43	431	368	28	442	345	570	900
225M	2	356	311	149	55	110	16	49	225	18.5	84	30.5	431	368	28	442	345	570	900
225M	4~8	356	311	149	60	140	18	53	225	18.5	84	30.5	431	368	28	442	345	570	925
250M	2	406	349	168	60	140	18	53	250	24	80	43	484	421	30	488	446	671	950
250M	4~8	406	349	168	65	140	18	58	250	24	80	43	484	421	30	488	446	671	950
280S	2	457	368	190	65	140	18	58	280	24	84	55	542	460	35	547	449	728	1007
280S	4~8	457	368	190	75	140	20	67.5	280	24	84	55	542	460	35	547	449	728	1007
280M	2	457	419	190	65	140	18	58	280	24	84	58.5	542	515	35	547	449	728	1055
280M	4~8	457	419	190	75	140	20	67.5	280	24	84	58.5	542	515	35	547	449	728	1055
315S	2	508	406	216	65	140	18	58	315	28	115	46	628	540	40	631	507	822	1190
315S	4~8	508	406	216	80	170	22	71	315	28	115	46	628	540	40	631	507	822	1220
315M	2	508	457	216	65	140	18	58	315	28	115	46	628	640	40	631	507	822	1290
315M	4~8	508	457	216	80	170	22	71	315	28	115	46	628	640	40	631	507	822	1320
315L	2	508	508	216	65	140	18	58	315	28	115	46	628	640	40	631	507	822	1290
315L	4~8	508	508	216	80	170	22	71	315	28	115	46	628	640	40	631	507	822	1320
355M	2	610	560	254	75	140	20	67.5	355	28	146	40.5	740	700	45	709	644	999	1432
355M	4~8	610	560	254	95	170	25	86	355	28	146	40.5	740	700	45	709	644	999	1462
355L	2	610	630	254	75	140	20	67.5	355	28	146	49	740	887	45	709	644	999	1602
355L	4~8	610	630	254	95	170	25	86	355	28	146	49	740	887	45	709	644	999	1632
3551	2	610	630	254	75	140	20	67.5	355	28	146	49	740	887	45	709	644	999	1602
3551	4,6	610	630	254	95	170	25	86	355	28	146	49	740	887	45	709	644	999	1632

WE4 Foot (B3) mounted, aluminium motor

Frame	Poles	Mounting dimensions (mm)									Boundary dimension (mm)								
		A	B	C	D	E	F	G	H	K	LA	LB	AB	BB	HA	AC	AD	HD	L
63M	2~6	100	80	40	11	23	4	8.5	63	7	25	10	125	100	2.5	127	114	177	238
71M	2~6	112	90	45	14	30	5	11	71	7	23	12.5	138	115	2.5	144	118	189	282
80M	2~6	125	100	50	19	40	6	15.5	80	4-10*12	38.5	12.5	156	125	10	160	131	211	335
90S	2~6	140	100	56	24	50	8	20	90	4-10*12	39.5	16.6	172	150	13	177	149	244	341
90L	2~6	140	125	56	24	50	8	20	90	4-10*12	39.5	16.6	172	175	13	177	149	244	368
100L	2~6	160	140	63	28	60	8	24	100	4-12*14	46.5	19	200	198	13	208	163	268	424
112M	2~6	190	140	70	28	60	8	24	112	4-12*14	56.5	19	228	201	15	226	189	305	461
132S	2~6	216	140	89	38	80	10	33	132	4-12*14	60	45	262	230	18	260	210	345	450
132M	4,6	216	178	89	38	80	10	33	132	4-12*14	60	36	262	250	18	260	210	345	490
160M	2~6	254	210	108	42	110	12	37	160	4-14.5*16.5	69.5	27	314	280	20	320	260	422	620
160L	2~6	254	254	108	42	110	12	37	160	4-14.5*16.5	69.5	27	314	324	20	320	260	422	665

WE3 Foot (B3) mounted, cast iron motor

Frame	Poles	Mounting dimensions (mm)									Boundary dimension (mm)								
		A	B	C	D	E	F	G	H	K	LA	LB	AB	BB	HA	AC	AD	HD	L
80M	2~8	125	100	50	19	40	6	15.5	80	10	32	15	157	146	10	163	136	221	299
90S	2~8	140	100	56	24	50	8	20	90	10	37	16.6	172	153	12	177	149	244	329
90L	2~8	140	125	56	24	50	8	20	90	10	37	16.6	172	175	12	177	149	244	351
100L	2~8	160	140	63	28	60	8	24	100	12	45	19	200	198	15	208	163	268	401
112M	2~8	190	140	70	28	60	8	24	112	12	45	19	228	201	15	226	189	305	417
132S	2~8	216	140	89	38	80	10	33	132	12	56.5	21.5	262	184	18	252	203	340	454
132M	4~8	216	178	89	38	80	10	33	132	12	56.5	21.5	262	222	18	252	203	340	492
160M	2~8	254	210	108	42	110	12	37	160	14.5	65	46	314	280	20	318	256	421	590
160L	2~8	254	254	108	42	110	12	37	160	14.5	65	46	314	324	20	318	256	421	634
180M	2,4	279	241	121	48	110	14	42.5	180	14.5	68	26.5	349	297	22	360	279	463	655
180L	4~8	279	279	121	48	110	14	42.5	180	14.5	68	26.5	349	335	22	360	279	463	693
200L	2~8	318	305	133	55	110	16	49	200	18.5	84	30	388	380	25	396	321	526	796
225S	4	356	286	149	60	140	18	53	225	18.5	84	43	431	368	28	442	345	570	846
225M	2	356	311	149	55	110	16	49	225	18.5	84	30.5	431	368	28	442	345	570	841
225M	4~8	356	311	149	60	140	18	53	225	18.5	84	30.5	431	368	28	442	345	570	871
250M	2	406	349	168	60	140	18	53	250	24	80	43	484	421	30	488	421	671	929
250M	4~8	406	349	168	65	140	18	58	250	24	80	43	484	421	30	488	421	671	929
280S	2	457	368	190	65	140	18	58	280	24	84	55	542	460	35	547	449	728	1007
280S	4~8	457	368	190	75	140	20	67.5	280	24	84	55	542	460	35	547	449	728	1007
280M	2	457	419	190	65	140	18	58	280	24	84	58.5	542	515	35	547	449	728	1055
280M	4~8	457	419	190	75	140	20	67.5	280	24	84	58.5	542	515	35	547	449	728	1055
315S	2	508	406	216	65	140	18	58	315	28	115	46	628	540	40	631	507	822	1190
315S	4~8	508	406	216	80	170	22	71	315	28	115	46	628	540	40	631	507	822	1220
315M	2	508	457	216	65	140	18	58	315	28	115	46	628	640	40	631	507	822	1290
315M	4~8	508	457	216	80	170	22	71	315	28	115	46	628	640	40	631	507	822	1320
315L	2	508	508	216	65	140	18	58	315	28	115	46	628	640	40	631	507	822	1290
315L	4~8	508	508	216	80	170	22	71	315	28	115	46	628	640	40	631	507	822	1320
355M	2	610	560	254	75	140	20	67.5	355	28	146	40.5	740	700	45	709	644	999	1432
355M	4~8	610	560	254	95	170	25	86	355	28	146	40.5	740	700	45	709	644	999	1462
355L	2	610	630	254	75	140	20	67.5	355	28	146	49	740	887	45	709	644	999	1602
355L	4~8	610	630	254	95	170	25	86	355	28	146	49	740	887	45	709	644	999	1632
3551/3552	2	610	630	254	75	140	20	67.5	355	28	146	49	740	887	45	709	644	999	1602
3551/3552	4~8	610	630	254	95	170	25	86	355	28	146	49	740	887	45	709	644	999	1632

WE3 Foot (B3) mounted, aluminium motor

Frame	Poles	Mounting dimensions (mm)									Boundary dimension (mm)								
		A	B	C	D	E	F	G	H	K	LA	LB	AB	BB	HA	AC	AD	HD	L
63M	2~6	100	80	40	11	23	4	8.5	63	7	25	10	125	100	2.5	127	114	177	238
71M	2~6	112	90	45	14	30	5	11	71	7	23	12.5	138	115	2.5	142	119	190	280
80M	2~6	125	100	50	19	40	6	15.5	80	4-10*12	38.5	12.5	156	125	10	160	131	211	315
90S	2~6	140	100	56	24	50	8	20	90	4-10*12	39.5	16.6	172	150	13	177	149	244	329
90L	2~6	140	125	56	24	50	8	20	90	4-10*12	39.5	16.6	172	175	13	177	149	244	351
100L	2~6	160	140	63	28	60	8	24	100	4-12*14	46.5	19	200	198	13	208	163	268	401
112M	2~6	190	140	70	28	60	8	24	112	4-12*14	56.5	19	228	201	15	226	189	305	417
132S	2~6	216	140	89	38	80	10	33	132	4-12*14	60	45	262	230	18	260	210	345	450
132M	4,6	216	178	89	38	80	10	33	132	4-12*14	60	36	262	250	18	260	210	345	490
160M	2~6	254	210	108	42	110	12	37	160	4-14.5*16.5	69.5	27	314	280	20	320	260	422	620
160L	2~6	254	254	108	42	110	12	37	160	4-14.5*16.5	69.5	27	314	324	20	320	260	422	665

Motor installation and dimensions B35

Foot & D Flange (B35) mounted - frame sizes 63~355

IM B35
IM 2001
63~100

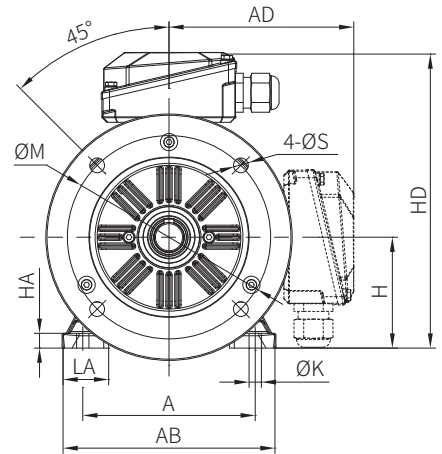
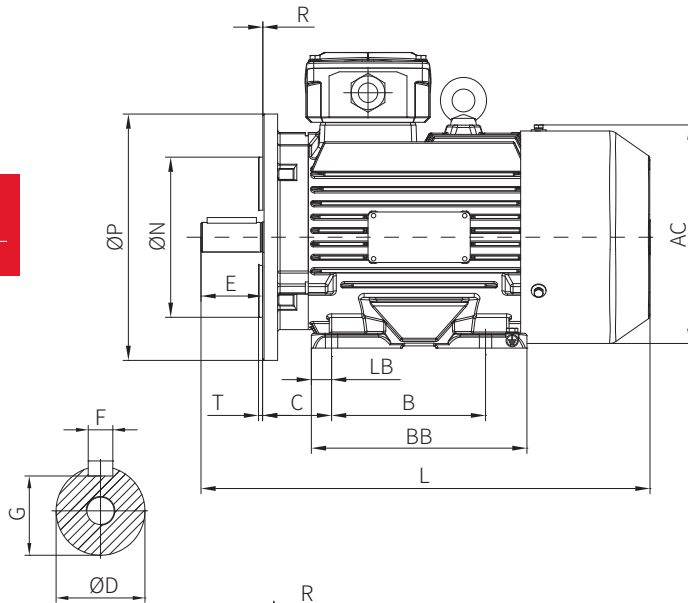

IM B35
IM 2001
112~200

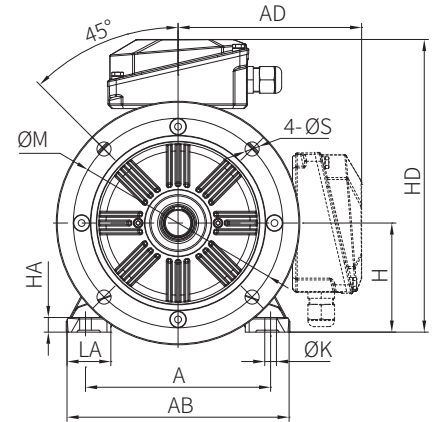
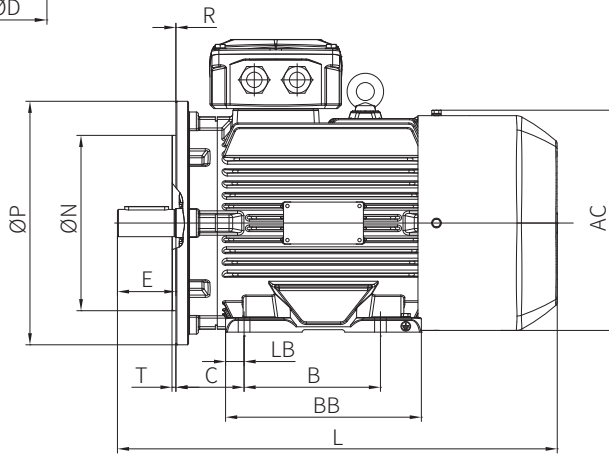

IM B35
IM 2001
225~355

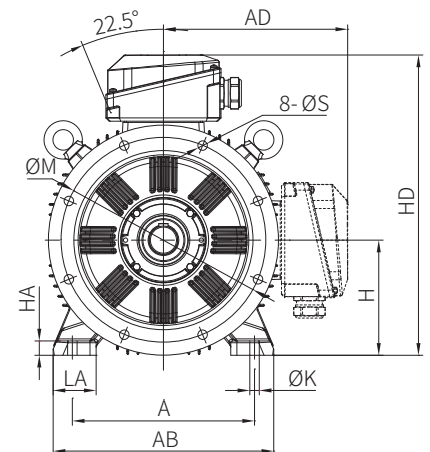
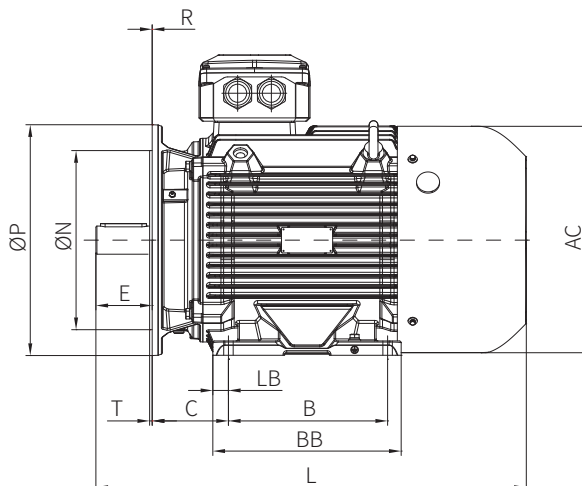

WE5 Foot (B35) mounted, cast iron motor

Frame	Poles	Mounting dimensions and tolerances (mm)															Boundary dimension (mm)									
		A	A/2	B	C	D	E	F	G	H	K	M	N	P	R	S	T	LA	LB	AB	BB	HA	AC	AD	HD	L
80M	2-8	125	62.5	100	50	19	40	6	15.5	80	10	165	130	200	0	12	3.5	32	15	157	190	10	163	141	221	340
90S	2-8	140	70	100	56	24	50	8	20	90	10	165	130	200	0	12	3.5	37	16.6	172	164	12	177	155	245	355
90L	2-8	140	70	125	56	24	50	8	20	90	10	165	130	200	0	12	3.5	37	16.6	172	190	12	177	155	245	395
100L	2-8	160	80	140	63	28	60	8	24	100	12	215	180	250	0	14.5	4	45	18	200	215.5	15	215	175	275	440
112M	2-8	190	95	140	70	28	60	8	24	112	12	215	180	250	0	14.5	4	45	28.5	228	220	15	215	193	305	450
132S	2-8	216	108	140	89	38	80	10	33	132	12	265	230	300	0	14.5	4	56.5	16.5	262	200	18	280	228	360	490
132M	2-8	216	108	178	89	38	80	10	33	132	12	265	230	300	0	14.5	4	56.5	16.5	262	258	18	280	228	360	545
160M	2-8	254	127	210	108	42	110	12	37	160	14.5	300	250	350	0	18.5	5	65	23	314	316	20	325	280	440	660
160L	2-8	254	127	254	108	42	110	12	37	160	14.5	300	250	350	0	18.5	5	65	23	314	386	20	325	280	440	730
180M	2-8	279	139.5	241	121	48	110	14	42.5	180	14.5	300	250	350	0	18.5	5	68	26.5	349	325	22	368	300	480	720
180L	2-8	279	139.5	279	121	48	110	14	42.5	180	14.5	300	250	350	0	18.5	5	68	26.5	349	360	22	368	300	480	760
200L	2-8	318	159	305	133	55	110	16	49	200	18.5	350	300	400	0	18.5	5	84	30	388	370	25	415	345	545	805
225S	4, 8	356	178	286	149	60	140	18	53	225	18.5	400	350	450	0	18.5	5	84	30.5	431	370	28	460	375	600	845
225M	2	356	178	311	149	55	110	16	49	225	18.5	400	350	450	0	18.5	5	84	30.5	431	415	28	460	375	600	860
225M	4-8	356	178	311	149	60	140	18	53	225	18.5	400	350	450	0	18.5	5	84	30.5	431	415	28	460	375	600	890
250M	2	406	203	349	168	60	140	18	53	250	24	500	450	550	0	18.5	5	80	43	484	421	30	501	435	685	920
250M	4-8	406	203	349	168	65	140	18	58	250	24	500	450	550	0	18.5	5	80	43	484	421	30	501	435	685	920
280S	2	457	228.5	368	190	65	140	18	58	280	24	500	450	550	0	18.5	5	84	58.5	542	467	35	562	470	750	985
280S	4-8	457	228.5	368	190	75	140	20	67.5	280	24	500	450	550	0	18.5	5	84	58.5	542	467	35	562	470	750	985
280M	2	457	228.5	419	190	65	140	18	58	280	24	500	450	550	0	18.5	5	84	58.5	542	515	35	562	470	750	1035
280M	4-8	457	228.5	419	190	75	140	20	67.5	280	24	500	450	550	0	18.5	5	84	58.5	542	515	35	562	470	750	1035
315S	2	508	254	406	216	65	140	18	58	315	28	600	550	660	0	24	6	120	61	628	670	45	646	525	840	1285
315S	4-8	508	254	406	216	80	170	22	71	315	28	600	550	660	0	24	6	120	61	628	670	45	646	525	840	1315
315M	2	508	254	457	216	65	140	18	58	315	28	600	550	660	0	24	6	120	61	628	770	45	646	525	840	1385
315M	4-8	508	254	457	216	80	170	22	71	315	28	600	550	660	0	24	6	120	61	628	770	45	646	525	840	1415
315L	2	508	254	508	216	65	140	18	58	315	28	600	550	660	0	24	6	120	61	628	770	45	646	525	840	1385
315L	4-8	508	254	508	216	80	170	22	71	315	28	600	550	660	0	24	6	120	61	628	770	45	646	525	840	1415
355M	2	630	315	630	254	75	140	20	67.5	355	28	740	680	800	0	24	6	150	41	766	875	45	740	665	1020	1580
355M	4-8	630	315	630	254	95	170	25	86	355	28	740	680	800	0	24	6	150	41	766	875	45	740	665	1020	1610
355L	2	630	315	710	254	75	140	20	67.5	355	28	740	680	800	0	24	6	150	49	766	985	45	740	665	1020	1690
355L	4-8	630	315	710	254	95	170	25	86	355	28	740	680	800	0	24	6	150	49	766	985	45	740	665	1020	1720
3551	2	630	315	710	254	75	140	20	67.5	355	28	740	680	800	0	24	6	150	49	766	985	45	740	665	1020	1690
3552	4-8	630	315	710	254	95	170	25	86	355	28	740	680	800	0	24	6	150	49	766	985	45	740	665	1020	1720

WE4 Foot (B35) mounted, cast iron motor

Frame	Poles	Mounting dimensions and tolerances (mm)															Boundary dimension (mm)									
		A	B	C	D	E	F	G	H	K	M	N	P	R	S	T	LA	LB	AB	BB	HA	AC	AD	HD	L	
80M	2-8	125	100	50	19	40	6	15.5	80	10	165	130	200	0±1.5	12	3.5	32	15	157	146	10	163	136	221	320	
90S	2-8	140	100	56	24	50	8	20	90	10	165	130	200	0±1.5	12	3.5	37	16.6	172	153	12	177	149	244	345	
90L	2-8	140	125	56	24	50	8	20	90	10	165	130	200	0±1.5	12	3.5	37	16.6	172	175	12	177	149	244	370	
100L	2-8	160	140	63	28	60	8	24	100	12	215	180	250	0±2.0	14.5	4	45	19	200	198	15	208	163	268	420	
112M	2-8	190	140	70	28	60	8	24	112	12	215	180	250	0±2.0	14.5	4	45	19	228	201	15	226	189	305	465	
132S	2-8	216	140	89	38	80	10	33	132	12	265	230	300	0±2.0	14.5	4	56.5	21.5	262	184	18	260	210	345	450	
132M	4-8	216	178	89	38	80	10	33	132	12	265	230	300	0±2.0	14.5	4	56.5	21.5	262	222	18	260	210	345	490	
160M	2-8	254	210	108	42	110	12	37	160	14.5	300	250	350	0±3.0	18.5	5	65	27	314	280	20	320	260	422	620	
160L	2-8	254	254	108	42	110	12	37	160	14.5	300	250	350	0±3.0	18.5	5	65	27	314	324	20	320	260	422	665	
180M	2,4	279	241	121	48	110	14	42.5	180	14.5	300	250	350	0±3.0	18.5	5	68	26.5	349	297	22	360	279	463	735	
180L	4-8	279	279	121	48	110	14	42.5	180	14.5	300	250	350	0±3.0	18.5	5	68	26.5	349	335	22	360	279	463	770	
200L	2-8	318	305	133	55	110	16	49	200	18.5	350	300	400	0±3.0	18.5	5	84	30	388	380	25	396	321	526	845	
225S	4,8	356	286	149	60	140	18	53	225	18.5	400	350	450	0±4.0	18.5	5	84	43	431	368	28	442	345	570	900	
225M	2	356	311	149	55	110	16	49	225	18.5	400	350	450	0±4.0	18.5	5	84	30.5	431	368	28	442	345	570	900	
225M	4-8	356	311	149	60	140	18	53	225	18.5	400	350	450	0±4.0	18.5	5	84	30.5	431	368	28	442	345	570	925	
250M	2	406	349	168	60	140	18	53	250	24	500	450	550	0±4.0	18.5	5	80	43	484	421	30	488	421	671	950	
250M	4-8	406	349	168	65	140	18	58	250	24	500	450	550	0±4.0	18.5	5	80	43	484	421	30	488	421	671	950	
280S	2	457	368	190	65	140	18	58	280	24	500	450	550	0±4.0	18.5	5	84	55	542	460	35	547	449	728	1007	
280S	4-8	457	368	190	75	140	20	67.5	280	24	500	450	550	0±4.0	18.5	5	84	55	542	460	35	547	449	728	1007	
280M	2	457	419	190	65	140	18	58	280	24	500	450	550	0±4.0	18.5	5	84	58.5	542	515	35	547	449	728	1055	
280M	4-8	457	419	190	75	140	20	67.5	280	24	500	450	550	0±4.0	18.5	5	84	58.5	542	515	35	547	449	728	1055	
315S	2	508	406	216	65	140	18	58	315	28	600	550	660	0±4.0	24	6	115	46	628	540	40	631	507	822	1190	
315S	4-8	508	406	216	80	170	22	71	315	28	600	550	660	0±4.0	24	6	115	46	628	540	40	631	507	822	1220	
315M	2	508	457	216	65	140	18	58	315	28	600	550	660	0±4.0	24	6	115	46	628	640	40	631	507	822	1290	
315M	4-8	508	457	216	80	170	22	71	315	28	600	550	660	0±4.0	24	6	115	46	628	640	40	631	507	822	1320	
315L	2	508	508	216	65	140	18	58	315	28	600	550	660	0±4.0	24	6	115	46	628	640	40	631	507	822	1290	
315L	4-8	508	508	216	80	170	22	71	315	28	600	550	660	0±4.0	24	6	115	46	628	640	40	631	507	822	1320	
355M	2	610	560	254	75	140	20	67.5	355	28	740	680	800	0±4.0	24	6	146	40.5	740	700	45	709	644	999	1432	
355M	4-8	610	560	254	95	170	25	86	355	28	740	680	800	0±4.0	24	6	146	40.5	740	700	45	709	644	999	1462	
355L	2	610	630	254	75	140	20	67.5	355	28	740	680	800	0±4.0	24	6	146	49	740	887	45	709	644	999	1602	
355L	4-8	610	630	254	95	170	25	86	355	28	740	680	800	0±4.0	24	6	146	49	740	887	45	709	644	999	1632	
3551	2	610	630	254	75	140	20	67.5	355	28	740	680	800	0±4.0	24	6	146	49	740	887	45	709	644	999	1602	
3551	4,6	610	630	254	95	170	25	86	355	28	740	680	800	0±4.0	24	6	146	49	740	887	45	709	644	999	1632	

WE4 Foot (B35) mounted, aluminium motor

Frame	Poles	Mounting dimensions and tolerances (mm)															Boundary dimension (mm)									
		A	B	C	D	E	F	G	H	K	M	N	P	R	S	T	LA	LB	AB	BB	HA	AC	AD	HD	L	
63M	2-6	100	80	40	11	23	4	8.5	63	7	115	95	140	0±1.5	10	3	25	10	125	100	2.5	127	114	177	238	
71M	2-6	112	90	45	14	30	5	11	71	7	130	110	160	0±1.5	10	3.5	23	12.5	138	115	2.5	144	118	189	282	
80M	2-6	125	100	50	19	40	6	15.5	80	4-10*12	165	130	200	0±1.5	12	3.5	38.5	12.5	156	125	10	160	131	211	335	
90S	2-6	140	100	56	24	50	8	20	90	4-10*12	165	130	200	0±1.5	12	3.5	39.5	16.6	172	150	13	177	149	244	341	
90L	2-6	140	125	56	24	50	8	20	90	4-10*12	165	130	200	0±1.5	12	3.5	39.5	16.6	172	175	13	177	149	244	368	
100L	2-6	160	140	63	28	60	8	24	100	4-12*14	215	180	250	0±2.0	14.5	4	46.5	19	200	198	13	208	163	268	424	
112M	2-6	190	140	70	28	60	8	24	112	4-12*14	215	180	250	0±2.0	14.5	4	56.5	19	228	201	15	226	189	305	461	
132S	2-6	216	140	89	38	80	10	33	132	4-12*14	265	230	300	0±2.0	14.5	4	60	45	262	230	18	260	210	345	450	
132M	4,6	216	178	89	38	80	10	33	132	4-12*14	265	230	300	0±2.0	14.5	4	60	36	262	250	18	260	210	345	490	
160M	2-6	254	210	108	42	110	12	37	160	4-14.5*16.5	300	250	350	0±3.0	18.5	5	69.5	27	314	280	20	320	260	422	620	
160L	2-6	254	254	108	42	110	12	37	160	4-14.5*16.5	300	250	350	0±3.0	18.5	5	69.5	27	314	324	20	320	260	422	665	

WE3 Foot (B35) mounted, cast iron motor

Frame	Poles	Mounting dimensions and tolerances (mm)															Boundary dimension (mm)									
		A	B	C	D	E	F	G	H	K	M	N	P	R	S	T	LA	LB	AB	BB	HA	AC	AD	HD	L	
80M	2-8	125	100	50	19	40	6	15.5	80	10	165	130	200	0±1.5	12	3.5	32	15	157	146	10	163	136	221	299	
90S	2-8	140	100	56	24	50	8	20	90	10	165	130	200	0±1.5	12	3.5	37	16.6	172	153	12	177	149	244	329	
90L	2-8	140	125	56	24	50	8	20	90	10	165	130	200	0±1.5	12	3.5	37	16.6	172	175	12	177	149	244	351	
100L	2-8	160	140	63	28	60	8	24	100	12	215	180	250	0±2.0	14.5	4	45	19	200	198	15	208	163	268	401	
112M	2-8	190	140	70	28	60	8	24	112	12	215	180	250	0±2.0	14.5	4	45	19	228	201	15	226	189	305	417	
132S	2-8	216	140	89	38	80	10	33	132	12	265	230	300	0±2.0	14.5	4	56.5	21.5	262	184	18	252	203	340	454	
132M	4-8	216	178	89	38	80	10	33	132	12	265	230	300	0±2.0	14.5	4	56.5	21.5	262	222	18	252	203	340	492	
160M	2-8	254	210	108	42	110	12	37	160	14.5	300	250	350	0±3.0	18.5	5	65	46	314	280	20	318	256	421	590	
160L	2-8	254	254	108	42	110	12	37	160	14.5	300	250	350	0±3.0	18.5	5	65	46	314	324	20	318	256	421	634	
180M	2,4	279	241	121	48	110	14	42.5	180	14.5	300	250	350	0±3.0	18.5	5	68	26.5	349	297	22	360	279	463	655	
180L	4-8	279	279	121	48	110	14	42.5	180	14.5	300	250	350	0±3.0	18.5	5	68	26.5	349	335	22	360	279	463	693	
200L	2-8	318	305	133	55	110	16	49	200	18.5	350	300	400	0±3.0	18.5	5	84	30	388	380	25	396	321	526	796	
225S	4	356	286	149	60	140	18	53	225	18.5	400	350	450	0±4.0	18.5	5	84	43	431	368	28	442	345	570	846	
225M	2	356	311	149	55	110	16	49	225	18.5	400	350	450	0±4.0	18.5	5	84	30.5	431	368	28	442	345	570	841	
225M	4-8	356	311	149	60	140	18	53	225	18.5	400	350	450	0±4.0	18.5	5	84	30.5	431	368	28	442	345	570	841	
250M	2	406	349	168	60	140	18	53	250	24	500	450	550	0±4.0	18.5	5	80	43	484	421	30	488	421	671	929	
250M	4-8	406	349	168	65	140	18	58	250	24	500	450	550	0±4.0	18.5	5	80	43	484	421	30	488	421	671	929	
280S	2	457	368	190	65	140	18	58	280	24	500	450	550	0±4.0	18.5	5	84	55	542	460	35	547	449	728	1007	
280S	4-8	457	368	190	75	140	20	67.5	280	24	500	450	550	0±4.0	18.5	5	84	55	542	460	35	547	449	728	1007	
280M	2	457	419	190	65	140	18	58	280	24	500	450	550	0±4.0	18.5	5	84	58.5	542	515	35	547	449	728	1055	
280M	4-8	457	419	190	75	140	20	67.5	280	24	500	450	550	0±4.0	18.5	5	84	58.5	542	515	35	547	449	728	1055	
315S	2	508	406	216	65	140	18	58	315	28	600	550	660	0±4.0	24	6	115	46	628	540	40	631	507	822	1190	
315S	4-8	508	406	216	80	170	22	71	315	28	600	550	660	0±4.0	24	6	115	46	628	540	40	631	507	822	1220	
315M	2	508	457	216	65	140	18	58	315	28	600	550	660	0±4.0	24	6	115	46	628	640	40	631	507	822	1290	
315M	4-8	508	457	216	80	170	22	71	315	28	600	550	660	0±4.0	24	6	115	46	628	640	40	631	507	822	1320	
315L	2	508	508	216	65	140	18	58	315	28	600	550	660	0±4.0	24	6	115	46	628	640	40	631	507	822	1290	
315L	4-8	508	508	216	80	170	22	71	315	28	600	550	660	0±4.0	24	6	115	46	628	640	40	631	507	822	1320	
355M	2	610	560	254	75	140	20	67.5	355	28	740	680	800	0±4.0	24	6	146	40.5	740	700	45	709	644	999	1432	
355M	4-8	610	560	254	95	170	25	86	355	28	740	680	800	0±4.0	24	6	146	40.5	740	700	45	709	644	999	1462	
355L	2	610	630	254	75	140	20	67.5	355	28	740	680	800	0±4.0	24	6	146	49	740	887	45	709	644	999	1602	
355L	4-8	610	630	254	95	170	25	86	355	28	740	680	800	0±4.0	24	6	146	49	740	887	45	709	644	999	1632	
3551/3552	2	610	630	254	75	140	20	67.5	355	28	740	680	800	0±4.0	24	6	146	49	740	887	45	709	644	999	1602	
3551/3552	4-8	610	630	254	95	170	25	86	355	28	740	680	800	0±4.0	24	6	146	49	740	887	45	709	644	999	1632	

WE3 Foot (B35) mounted, aluminium motor

Frame	Poles	Mounting dimensions and tolerances (mm)															Boundary dimension (mm)									
		A	B	C	D	E	F	G	H	K	M	N	P	R	S	T	LA	LB	AB	BB	HA	AC	AD	HD	L	
63M	2-6	100	80	40	11	23	4	8.5	63	7	115	95	140	0±1.5	10	3	25	10	125	100	2.5	127	114	177	238	
71M	2-6	112	90	45	14	30	5	11	71	7	130	110	160	0±1.5	10	3.5	23	12.5	138	115	2.5	142	119	190	280	
80M	2-6	125	100	50	19	40	6	15.5	80	4-10*12	165	130	200	0±1.5	12	3.5	38.5	12.5	156	125	10	160	131	211	315	
90S	2-6	140	100	56	24	50	8	20	90	4-10*12	165	130	200	0±1.5	12	3.5	39.5	16.6	172	150	13	177	149	244	329	
90L	2-6	140	125	56	24	50	8	20	90	4-10*12	165	130	200	0±1.5	12	3.5	39.5	16.6	172	175	13	177	149	244	351	
100L	2-6	160	140	63	28	60	8	24	100	4-12*14	215	180	250	0±2.0	14.5	4	46.5	19	200	198	13	208	163	268	401	
112M	2-6	190	140	70	28	60	8	24	112	4-12*14	215	180	250	0±2.0	14.5	4	56.5	19	228	201	15	226	189	305	417	
132S	2-6	216	140	89	38	80	10	33	132	4-12*14	265	230	300	0±2.0	14.5	4	60	45	262	230	18	260	210	345	450	
132M	4,6	216	178	89	38	80	10	33	132	4-12*14	265	230	300	0±2.0	14.5	4	60	36	262	250	18	260	210	345	490	
160M	2-6	254	210	108	42	110	12	37	160	4-14.5*16.5	300	250	350	0±3.0	18.5	5	69.5	27	314	280	20	320	260	422	620	
160L	2-6	254	254	108	42	110	12	37	160	4-14.5*16.5	300	250	350	0±3.0	18.5	5	69.5	27	314	324	20	320	260	422	665	

Motor installation and dimensions B5&V1

▼ D Flange, horizontal (B5) mounted - frame sizes 63~280 / D Flange, shaft down (V1) mounted - frame sizes 63~355

IM B5/IM V1
IM 3001/IM 3011
63~100

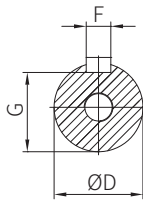
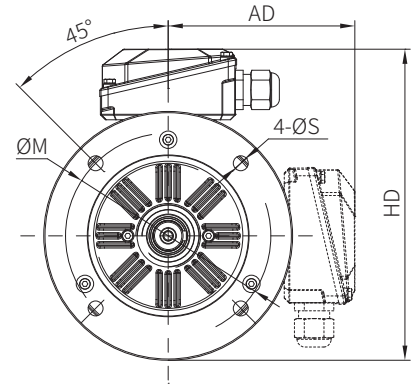
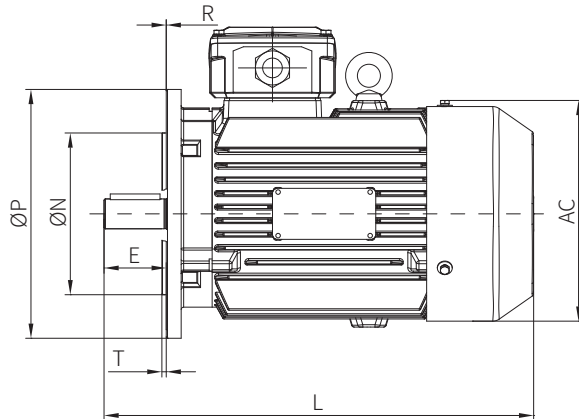

IM B5/IM V1
IM 3001/IM 3011
112~200

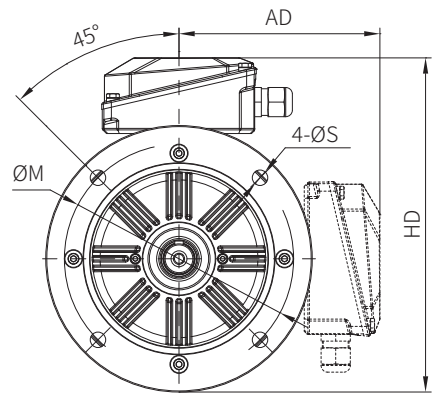
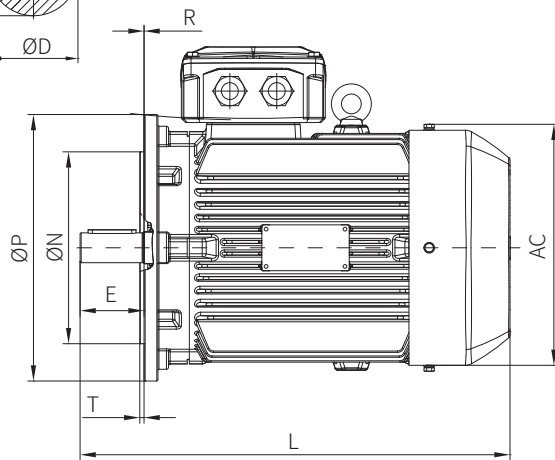

IM B5/IM V1
IM 3001/IM 3011
225~355

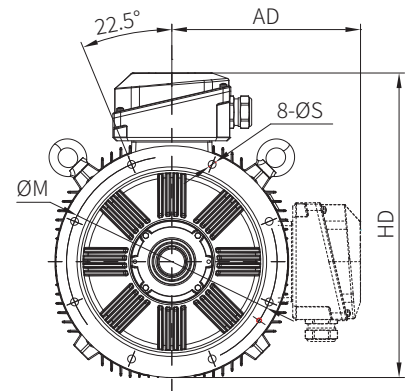
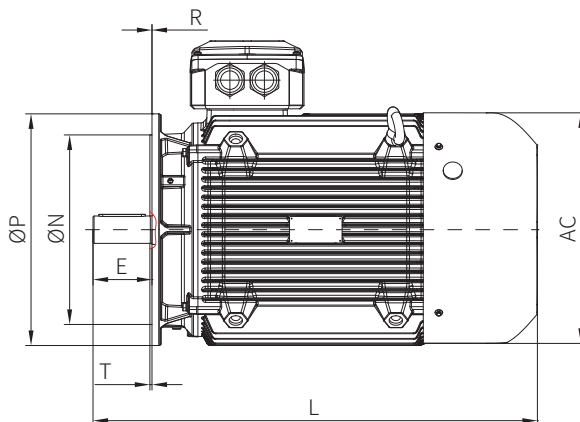

WE5 D Flange, horizontal (B5)/shaft down (V1) mounted, cast iron

Frame	Poles	Mounting dimensions and tolerances (mm)										Boundary dimension (mm)			
		D	E	F	G	M	N	P	R	S	T	AC	AD	HD	L
80M	2-8	19	40	6	15.5	165	130	200	0	12	3.5	163	141	240	340
90S	2-8	24	50	8	20	165	130	200	0	12	3.5	177	155	255	355
90L	2-8	24	50	8	20	165	130	200	0	12	3.5	177	155	255	395
100L	2-8	28	60	8	24	215	180	250	0	14.5	4	215	175	300	440
112M	2-8	28	60	8	24	215	180	250	0	14.5	4	215	193	325	450
132S	2-8	38	80	10	33	265	230	300	0	14.5	4	280	228	381	490
132M	2-8	38	80	10	33	265	230	300	0	14.5	4	280	228	381	545
160M	2-8	42	110	12	37	300	250	350	0	18.5	5	325	280	460	660
160L	2-8	42	110	12	37	300	250	350	0	18.5	5	325	280	460	730
180M	2-8	48	110	14	42.5	300	250	350	0	18.5	5	368	300	509	720
180L	2-8	48	110	14	42.5	300	250	350	0	18.5	5	368	300	509	760
200L	2-8	55	110	16	49	350	300	400	0	18.5	5	415	345	587	805
225S	4-8	60	140	18	53	400	350	450	0	18.5	5	460	375	632	845
225M	2	55	110	16	49	400	350	450	0	18.5	5	460	375	632	860
225M	4-8	60	140	18	53	400	350	450	0	18.5	5	460	375	632	890
250M	2	60	140	18	53	500	450	550	0	18.5	5	501	435	723	920
250M	4-8	65	140	18	58	500	450	550	0	18.5	5	501	435	723	920
280S	2	65	140	18	58	500	450	550	0	18.5	5	562	470	791	985
280S	4-8	75	140	20	67.5	500	450	550	0	18.5	5	562	470	791	985
280M	2	65	140	18	58	500	450	550	0	18.5	5	562	470	791	1035
280M	4-8	75	140	20	67.5	500	450	550	0	18.5	5	562	470	791	1035
315S	2	65	140	18	58	600	550	660	0	24	6	646	525	855	1285
315S	4-8	80	170	22	71	600	550	660	0	24	6	646	525	855	1315
315M	2	65	140	18	58	600	550	660	0	24	6	646	525	855	1385
315M	4-8	80	170	22	71	600	550	660	0	24	6	646	525	855	1415
315L	2	65	140	18	58	600	550	660	0	24	6	646	525	855	1385
315L	4-8	80	170	22	71	600	550	660	0	24	6	646	525	855	1415
355M	2	75	140	20	67.5	740	680	800	0	24	6	772	665	1010	1580
355M	4-8	95	170	25	86	740	680	800	0	24	6	772	665	1010	1610
355L	2	75	140	20	67.5	740	680	800	0	24	6	772	665	1010	1690
355L	4-8	95	170	25	86	740	680	800	0	24	6	772	665	1010	1720
3551	2	75	140	20	67.5	740	680	800	0	24	6	772	665	1010	1690
3552	4-8	95	170	25	86	740	680	800	0	24	6	772	665	1010	1720

WE4 D Flange, horizontal (B5)/shaft down (V1) mounted, cast iron

Frame	Poles	Mounting dimensions and tolerances (mm)										Boundary dimension (mm)			
		D	E	F	G	M	N	P	R	S	T	AC	AD	HD	L
80M	2~8	19	40	6	15.5	165	130	200	0±1.5	12	3.5	163	136	221	320
90S	2~8	24	50	8	20	165	130	200	0±1.5	12	3.5	177	149	244	345
90L	2~8	24	50	8	20	165	130	200	0±1.5	12	3.5	177	149	244	370
100L	2~8	28	60	8	24	215	180	250	0±2.0	14.5	4	208	163	268	420
112M	2~8	28	60	8	24	215	180	250	0±2.0	14.5	4	226	189	305	465
132S	2~8	38	80	10	33	265	230	300	0±2.0	14.5	4	260	210	345	450
132M	4~8	38	80	10	33	265	230	300	0±2.0	14.5	4	260	210	345	490
160M	2~8	42	110	12	37	300	250	350	0±3.0	18.5	5	320	260	422	620
160L	2~8	42	110	12	37	300	250	350	0±3.0	18.5	5	320	260	422	665
180M	2,4	48	110	14	42.5	300	250	350	0±3.0	18.5	5	360	279	463	735
180L	4~8	48	110	14	42.5	300	250	350	0±3.0	18.5	5	360	279	463	770
200L	2~8	55	110	16	49	350	300	400	0±3.0	18.5	5	396	321	526	845
225S	4,8	60	140	18	53	400	350	450	0±4.0	18.5	5	442	345	580	900
225M	2	55	110	16	49	400	350	450	0±4.0	18.5	5	442	345	580	900
225M	4~8	60	140	18	53	400	350	450	0±4.0	18.5	5	442	345	580	925
250M	2	60	140	18	53	500	450	550	0±4.0	18.5	5	488	446	671	950
250M	4~8	65	140	18	58	500	450	550	0±4.0	18.5	5	488	446	671	950
280S	2	65	140	18	58	500	450	550	0±4.0	18.5	5	547	449	723	1007
280S	4~8	75	140	20	67.5	500	450	550	0±4.0	18.5	5	547	449	723	1007
280M	2	65	140	18	58	500	450	550	0±4.0	18.5	5	547	449	723	1055
280M	4~8	75	140	20	67.5	500	450	550	0±4.0	18.5	5	547	449	723	1055
315S	2	65	140	18	58	600	550	660	0±4.0	24	6	631	507	850	1190
315S	4~8	80	170	22	71	600	550	660	0±4.0	24	6	631	507	850	1220
315M	2	65	140	18	58	600	550	660	0±4.0	24	6	631	507	850	1290
315M	4~8	80	170	22	71	600	550	660	0±4.0	24	6	631	507	850	1320
315L	2	65	140	18	58	600	550	660	0±4.0	24	6	631	507	850	1290
315L	4~8	80	170	22	71	600	550	660	0±4.0	24	6	631	507	850	1320
355M	2	75	140	20	67.5	740	680	800	0±4.0	24	6	709	644	1044	1432
355M	4~8	95	170	25	86	740	680	800	0±4.0	24	6	709	644	1044	1462
355L	2	75	140	20	67.5	740	680	800	0±4.0	24	6	709	644	1044	1602
355L	4~8	95	170	25	86	740	680	800	0±4.0	24	6	709	644	1044	1632
3551	2	75	140	20	67.5	740	680	800	0±4.0	24	6	709	644	1044	1602
3551	4,6	95	170	25	86	740	680	800	0±4.0	24	6	709	644	1044	1632

D Flange, horizontal (B5)/shaft down (V1) mounted, aluminium

Frame	Poles	Mounting dimensions and tolerances (mm)										Boundary dimension (mm)			
		D	E	F	G	M	N	P	R	S	T	AC	AD	HD	L
63M	2~6	11	23	4	8.5	115	95	140	0±1.5	10	3	127	114	184	238
71M	2~6	14	30	5	11	130	110	160	0±1.5	10	3.5	144	118	198	282
80M	2~6	19	40	6	15.5	165	130	200	0±1.5	12	3.5	160	131	231	335
90S	2~6	24	50	8	20	165	130	200	0±1.5	12	3.5	177	149	254	341
90L	2~6	24	50	8	20	165	130	200	0±1.5	12	3.5	177	149	254	368
100L	2~6	28	60	8	24	215	180	250	0±2.0	14.5	4	208	163	293	424
112M	2~6	28	60	8	24	215	180	250	0±2.0	14.5	4	226	189	318	461
132S	2~6	38	80	10	33	265	230	300	0±2.0	14.5	4	260	210	363	450
132M	4,6	38	80	10	33	265	230	300	0±2.0	14.5	4	260	210	363	490
160M	2~6	42	110	12	37	300	250	350	0±3.0	18.5	5	320	260	437	620
160L	2~6	42	110	12	37	300	250	350	0±3.0	18.5	5	320	260	437	665

WE3 D Flange, horizontal (B5)/shaft down (V1) mounted, cast iron

Frame	Poles	Mounting dimensions and tolerances (mm)										Boundary dimension (mm)			
		D	E	F	G	M	N	P	R	S	T	AC	AD	HD	L
80M	2-8	19	40	6	15.5	165	130	200	0±1.5	12	3.5	163	136	241	299
90S	2-8	24	50	8	20	165	130	200	0±1.5	12	3.5	177	149	254	329
90L	2-8	24	50	8	20	165	130	200	0±1.5	12	3.5	177	149	254	351
100L	2-8	28	60	8	24	215	180	250	0±2.0	14.5	4	208	163	293	401
112M	2-8	28	60	8	24	215	180	250	0±2.0	14.5	4	226	189	318	417
132S	2-8	38	80	10	33	265	230	300	0±2.0	14.5	4	252	203	358	454
132M	4-8	38	80	10	33	265	230	300	0±2.0	14.5	4	252	203	358	492
160M	2-8	42	110	12	37	300	250	350	0±3.0	18.5	5	318	256	436	590
160L	2-8	42	110	12	37	300	250	350	0±3.0	18.5	5	318	256	436	634
180M	2,4	48	110	14	42.5	300	250	350	0±3.0	18.5	5	360	279	458	655
180L	4-8	48	110	14	42.5	300	250	350	0±3.0	18.5	5	360	279	458	693
200L	2-8	55	110	16	49	350	300	400	0±3.0	18.5	5	396	321	526	796
225S	4	60	140	18	53	400	350	450	0±4.0	18.5	5	442	345	580	846
225M	2	55	110	16	49	400	350	450	0±4.0	18.5	5	442	345	580	841
225M	4-8	60	140	18	53	400	350	450	0±4.0	18.5	5	442	345	580	871
250M	2	60	140	18	53	500	450	550	0±4.0	18.5	5	488	421	696	929
250M	4-8	65	140	18	58	500	450	550	0±4.0	18.5	5	488	421	696	929
280S	2	65	140	18	58	500	450	550	0±4.0	18.5	5	547	449	723	1007
280S	4-8	75	140	20	67.5	500	450	550	0±4.0	18.5	5	547	449	723	1007
280M	2	65	140	18	58	500	450	550	0±4.0	18.5	5	547	449	723	1055
280M	4-8	75	140	20	67.5	500	450	550	0±4.0	18.5	5	547	449	723	1055
315S	2	65	140	18	58	600	550	660	0±4.0	24	6	631	507	850	1190
315S	4-8	80	170	22	71	600	550	660	0±4.0	24	6	631	507	850	1220
315M	2	65	140	18	58	600	550	660	0±4.0	24	6	631	507	850	1290
315M	4-8	80	170	22	71	600	550	660	0±4.0	24	6	631	507	850	1320
315L	2	65	140	18	58	600	550	660	0±4.0	24	6	631	507	850	1290
315L	4-8	80	170	22	71	600	550	660	0±4.0	24	6	631	507	850	1320
355M	2	75	140	20	67.5	740	680	800	0±4.0	24	6	709	644	1044	1432
355M	4-8	95	170	25	86	740	680	800	0±4.0	24	6	709	644	1044	1462
355L	2	75	140	20	67.5	740	680	800	0±4.0	24	6	709	644	1044	1602
355L	4-8	95	170	25	86	740	680	800	0±4.0	24	6	709	644	1044	1632
3551/3552	2	75	140	20	67.5	740	680	800	0±4.0	24	6	709	644	1044	1602
3551/3552	4-8	95	170	25	86	740	680	800	0±4.0	24	6	709	644	1044	1632

WE3 D Flange, horizontal (B5)/shaft down (V1) mounted, aluminium

Frame	Poles	Mounting dimensions and tolerances (mm)										Boundary dimension (mm)			
		D	E	F	G	M	N	P	R	S	T	AC	AD	HD	L
63M	2-6	11	23	4	8.5	115	95	140	0±1.5	10	3	127	114	184	238
71M	2-6	14	30	5	11	130	110	160	0±1.5	10	3.5	142	119	200	280
80M	2-6	19	40	6	15.5	165	130	200	0±1.5	12	3.5	160	131	231	315
90S	2-6	24	50	8	20	165	130	200	0±1.5	12	3.5	177	149	254	329
90L	2-6	24	50	8	20	165	130	200	0±1.5	12	3.5	177	149	254	351
100L	2-6	28	60	8	24	215	180	250	0±2.0	14.5	4	208	163	293	401
112M	2-6	28	60	8	24	215	180	250	0±2.0	14.5	4	226	189	315	417
132S	2-6	38	80	10	33	265	230	300	0±2.0	14.5	4	260	210	363	450
132M	4,6	38	80	10	33	265	230	300	0±2.0	14.5	4	260	210	363	490
160M	2-6	42	110	12	37	300	250	350	0±3.0	18.5	5	320	260	437	620
160L	2-6	42	110	12	37	300	250	350	0±3.0	18.5	5	320	260	437	665

Motor installation and dimensions B14&V18

WE3 C Face, horizontal (B14) / shaft down (V18) mounted - frame sizes 80~112 cast iron motor WE

IM B14/IM V18
IM 3601/IM 3611
80~100

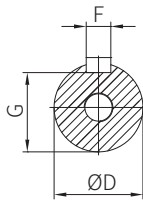
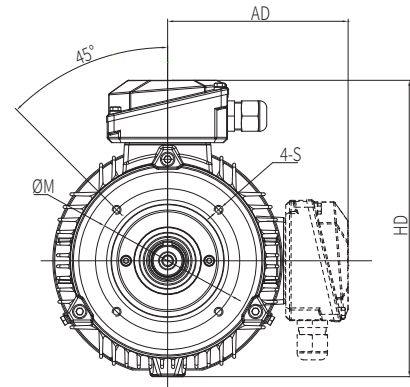
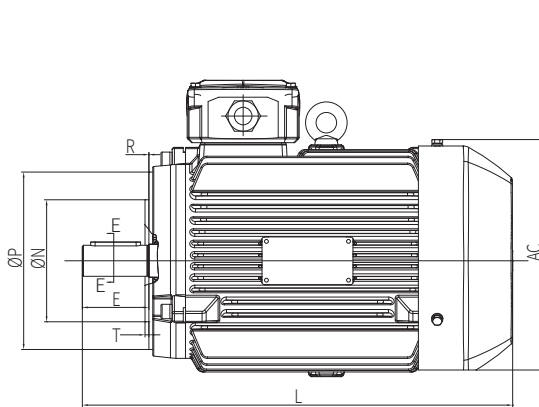

IM B14/IM V18
IM 3601/IM 3611
112

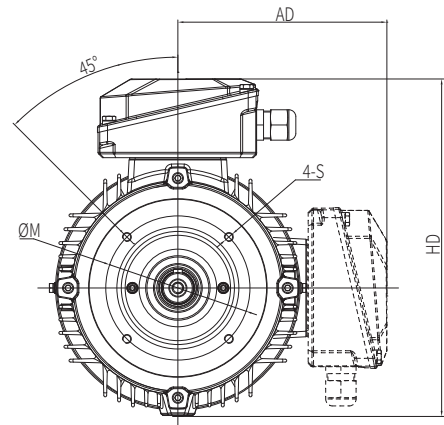
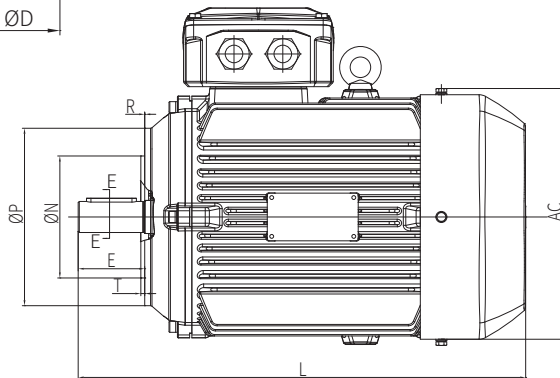

Frame	Poles	Mounting dimensions and tolerances (mm)										Boundary dimension (mm)			
		ØD	E	F	G	ØM	ØN	ØP	R	S	T	AC	AD	HD	L
80M	2-8	19	40	6	15.5	100	80	120	0±1.5	M6	3	163	147	230	299
90S	2-8	24	50	8	20	115	95	140	0±1.5	M8	3	177	153	249	329
90L	2-8	24	50	8	20	115	95	140	0±1.5	M8	3	177	153	249	351
100L	2-8	28	60	8	24	130	110	160	0±1.5	M8	3.5	208	167	274	401
112M	2-8	28	60	8	24	130	110	160	0±1.5	M8	3.5	226	187	308	417

WE3 C Face, horizontal(B14)/shaft down(V18)mounted - frame sizes 71~112 aluminium motor

IMB14/IMV18
IM3601/IM3611
71~100

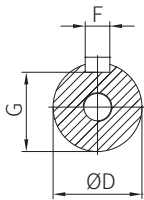
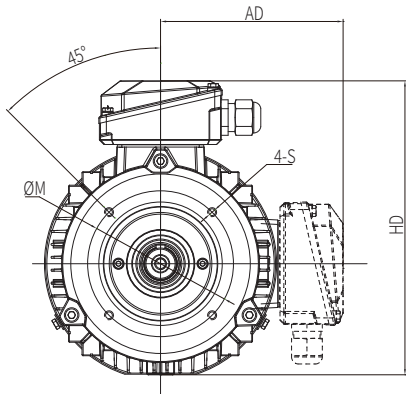
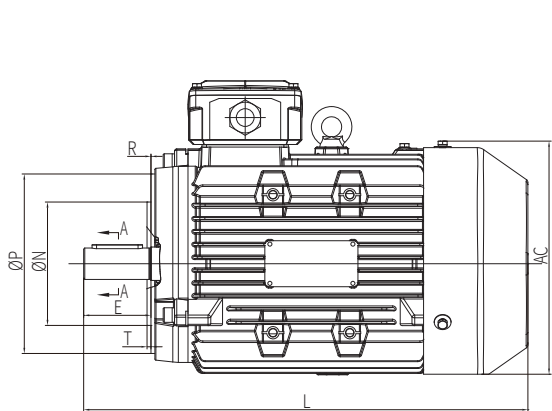



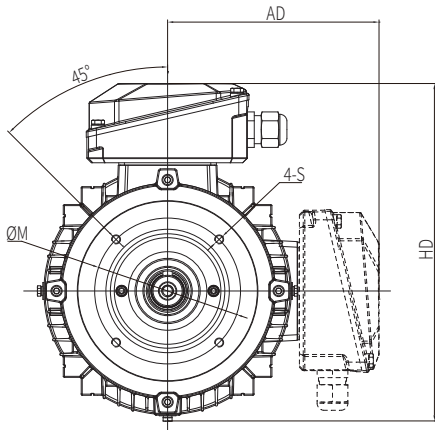
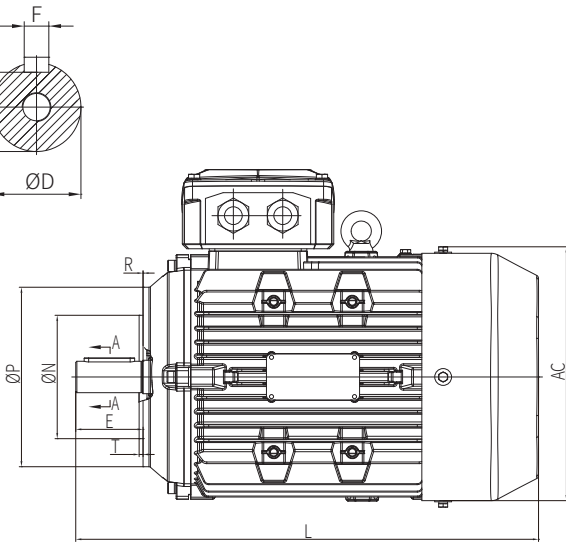



IMB14/IMV18
IM3601/IM3611
112











Frame	Poles	Mounting dimensions and tolerances (mm)										Boundary dimension (mm)			
		ØD	E	F	G	ØM	ØN	ØP	R	S	T	AC	AD	HD	L
71M	2-6	14	30	5	11	85	70	105	0±1.5	M6	2.5	142	119	191	280
80M	2-6	19	40	6	15.5	100	80	120	0±1.5	M6	3	160	131	211	315
90S	2-6	24	50	8	20	115	95	140	0±1.5	M8	3	177	153	249	329
90L	2-6	24	50	8	20	115	95	140	0±1.5	M8	3	177	153	249	351
100L	2-6	28	60	8	24	130	110	160	0±1.5	M8	3.5	208	167	274	401
112M	2-6	28	60	8	24	130	110	160	0±1.5	M8	3.5	226	187	308	417

Technical information

Mounting arrangements

Basic structural type	With foot, endshield without flange					
Mounting type code	B3	B6	B7	B8	V5	V6
Schematic diagram						
Frame	63-355		63-160			

Basic structural type	Without foot, endshield with flange			With foot, endshield with flange		
Mounting type code	B5	V1	V3	B35	V15	V36
Schematic diagram						
Frame	63-280	63-355	63-160	63-355	63-160	

Basic structural type	Without foot, endshield with a small flange		With foot, endshield with a small flange	
Mounting type code	B14	V18	B34	
Schematic diagram				
Frame	71-112			

Level of protection

WE series standard protection grade is IP55, IP56, IP65, IP66 and other protection grades can be customized according to customer requirements.

The protection level of the shell is mainly to prevent electric shock to human body or close to live parts or rotating parts, to prevent solid foreign matter from entering and to prevent harmful effects caused by water and oil, The code name and meaning of the protection form is shown in the table below.

Code	Meaning	First digit	Meaning	Second-order digit	Meaning
IP	Level of protection	5	Dust prevention	5	Prevent water spray
		6	Dust tight	6	Prevent strong spraying of water

Insulation grade and temperature rise limit

WE series adopts F grade insulation, and the temperature rise is assessed as B grade. Nano-insulation impregnating resin can be selected to further improve the service life in the power supply environment and service environment.

In order to run the motor reliably, insulation materials are needed to separate the live parts from the enclosure or live parts. Motor as an energy conversion or signal conversion element. There is energy loss in the process of operation itself, a portion of the energy losses caused by temperature rise from itself. Under the general condition, insulation class, suffering the most from extreme temperatures and the resistance method is used to measure the motor temperature rise limit between comply with the following table, the temperature rise limit within the motor should be able to work properly.

Insulation grade	Limited temperature°C	The temperature rise limit K
B	130	80
F	155	105
H	180	125

▼ Nameplate sample

		3~AC MOTOR IEC/EN 60034		IE5	
TYPE		IM		P/ No	
Th.Cl.		S	IP	kg	
Temp Rise B					
V Δ/ λ	Hz	kW	A Δ/ λ	cos φ	r /min η%
Made in China					

▼ Terminal box

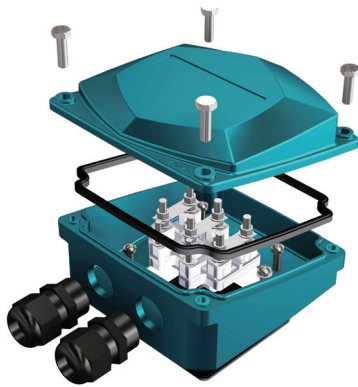
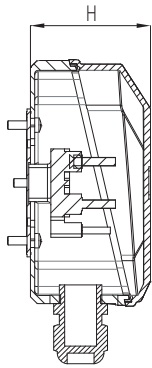
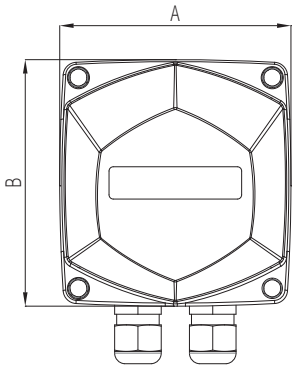

Frame	Boundary dimension AxBxH (mm)	Number and size of outlets	Diameter of single hole screw sleeve can lock the cable (mm)	Thread of terminal
63~80	90x96x50	1-M25x1.5	Φ8-Φ12	M4
90~100	102x110x57.5	1-M25x1.5	Φ8-Φ12	M4
112~132	136x146x72	2-M25x1.5	Φ8-Φ12	M5
160~180	171x181x91	2-M32x1.5	Φ16-Φ21	M6
200~225	220x230x113	2-M50x1.5	Φ32-Φ39	M8
250~280	270x280x162	2-M63x1.5	Φ37-Φ44	M10
315	312x329x175	2-M63x1.5	Φ37-Φ44	M12
355	382x402x200	2-M72x2	Φ45-Φ53	M16

▼ Lifting ring

Frame	WE3&WE4			WE5		
	Lifting ring	Quantity	Location	Lifting ring	Quantity	Location
63-71	-	-	-	-	-	-
80-90S	-	-	-	M8	1	Top (Horizontal mounting)
90L~112	M8	1	Both sides of terminal box Left front and right rear view from shaft end	M8	1	
132	M10	1		M10	1	
160	M12	1		M12	1	
180	M16	1		M16	1	
200~225	M20	2		M20	1	
250	M20	2		M24	1	Both sides of terminal box
280	M24	2	M30	1		
315	M30	2	M30	2		
355	M36	2	M36	2		

▼ WE3&WE4 Series Bearing type for aluminum motor

Frame	Poles	DE	NDE
63	2~4	6201ZZ	6201ZZ
71	2~6	6202ZZ	6202ZZ
80	2~6	6204ZZ	6204ZZ
90	2~6	6205ZZ	6203ZZ
100	2~6	6206ZZ	6205ZZ
112	2~6	6206ZZ	6206ZZ
132	2~6	6208ZZ	6208ZZ
160	2~6	6309ZZ	6309ZZ

▼ Bearing type for cast iron motor(WE3 series)

Frame	Poles	DE	NDE	Frame	Poles	DE	NDE
80	2~8	6204ZZ	6204ZZ	H225	4~8	6313	6312
90	2~8	6205ZZ	6203ZZ	H250	2	6313	6313
100	2~8	6206ZZ	6205ZZ	H250	4~8	6314	6313
112	2~8	6206ZZ	6206ZZ	H280	2	6314	6314
132	2~8	6208ZZ	6305ZZ	H280	4~8	6317	6314
160	2~8	6309ZZ	6307ZZ	H315	2	6317	6317
180	2~8	6310ZZ	6308ZZ	H315	4~8	6319	6319
200	2~8	6312	6212	H355	2	6319	6319
225	2	6312	6312	H355	4~8	6322	6322

Note:ZZ - Double shielded bearings.

The table above shows standard bearing sizes, alternative bearings are available if required.

▼ Bearing type for cast iron motor(WE4&WE5 series)

Frame	Poles	DE	NDE
80	2~8	6204ZZ	6204ZZ
90	2~8	6205ZZ	6205ZZ
100	2~8	6206ZZ	6206ZZ
112	2~8	6206ZZ	6206ZZ
132	2~8	6208ZZ	6208ZZ
160	2~8	6309ZZ	6309ZZ
180	2~8	6310ZZ	6310ZZ
200	2~8	6312	6312
225	2	6312	6312
225	4~8	6313	6312
250	2	6313	6313
250	4~8	6314	6313
280	2	6314	6314
280	4~8	6317	6314
315	2	6317	6317
315	4~8	6319	6319
355	2	6319	6319
355	4~8	6322	6322

▼ Permissible forces at the shaft end

Maximum radial force (for pulley drive system): The maximum allowable radial force F_0 (unit: N) for radial load is based on the premise that the load line (center of pulley) must be within the length of the motor shaft extension (the motor shaft elongation is shown in the installation size code E size). The radial force length X (mm) is the distance from the axial extension shoulder to the radial force F_0 action line, so when the length $X = \text{Max}$, it is the total length of the axial extension (size value E). Maximum allowable radial force as below table.

Frame	Radial force F_0 (N)							
	2P		4P		6P		8P	
	$X=0$	$X=\text{max}$	$X=0$	$X=\text{max}$	$X=0$	$X=\text{max}$	$X=0$	$X=\text{max}$
71	440	380	460	400	540	470	-	-
80	720	600	760	630	860	720	980	820
90	780	650	810	670	940	780	1060	880
100	1100	900	1110	910	1310	1070	1480	1210
112	1090	900	1080	890	1290	1060	1460	1200
132	1730	1360	1740	1400	2000	1610	2330	1880
160	2950	2330	3050	2410	3420	2700	3870	3060
180	3420	2740	3460	2820	4080	3320	4430	3610
200	4390	3640	4500	3730	5270	4370	5790	4800
225	4340	3620	5050	4030	5870	4690	6470	5170
250	4910	4000	5710	4650	6520	5310	7180	5840
280	5380	4500	6870	5750	8090	6770	9120	7630
315	6400	5550	7500	6310	8420	7080	9120	7670
355	6770	6070	8620	7560	9910	8690	11590	10160

Permissible radial force Frame sizes 80~355

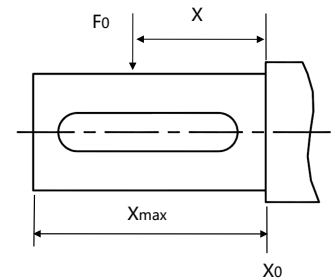

Optional accessories

Thermal protection device is optional for WE series.

Thermistor PTC

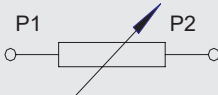
Name	PTC thermistor
Type	MZ6 160 D
Application	Motor overheating protection
Operating temperature and accuracy	160 ±5°C
Set position	1 in each phase, in series, at the highest temperature point embedded at the end of the winding at the drive end
Connection	Three components in series, two leads to the terminal box.
Color and marking of wiring	P1 & P2
Wiring diagram	
Frame	71~355

Note : (1) PTC operating temperature can be customized according to specifications.

(2) PTO thermosensitive bimetal switch can be used according to specifications.

Winding Resistant Temperature Detector (RTD)

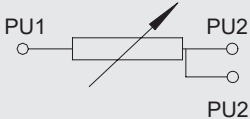
Name	Platinum Resistant Temperature Detector (RTD)
Type	PT100, three leads
Application	Motor winding temperature detection, high temperature protection
0°C resistance and precision	100± 0.12Ω (Class B tolerances)
Set position	1 in each phase, at the highest temperature point embedded at the end of the winding at the drive end
Connection	Each component has three lead wires to the terminal box
Lead Markings	U – PU1, PU2, PU2 ; V – PVI, PV2, PV2; W – PW1, PW2, PW2. If there are two elements in each phase winding, the lead of the other element is marked as: U – PU3, PU4, PU4 ; V – PV3, PV4, PV4 ; W – PW3, PW4, PW4
Wiring diagram	
Frame	160~355

▼ Bearing Resistant Temperature Detector (RTD)

Name	Platinum Resistant Temperature Detector (RTD)
Type	WZP-M, three leads, sealed metal body
Application	Motor winding temperature detection, over temperature protection
0°C resistance and precision	100± 0.12Ω (Class B tolerances)
Quantity	One per bearing
Set position	Embedded inside the endshield, the face of the sensor must contact the outer ring of the bearing
Connection	Each component has three lead wires to the terminal box.
Lead Markings	drive-end bearing (D E) — PDI, PD2, PD2 ; non-driven-end bearing (NDE) — PNI, PN2, PN2 If two elements are used for each end of the bearing, the lead of the other element is marked as: drive-end bearing (D E) - PD3, PD4, PD4 ; non-driven-end bearing (NDE) - PN3, PN4, Pn4
Wiring diagram	
Frame sizes	160-355

According to temperature measuring elements, K or T type thermocouples can be fitted as an alternative.

▼ Anti-condensation heater

Name	Anti-condensation heater											
Application	Prevent condensation within the motor, which would lead to low insulation resistance											
Temperature resistance of insulating material	≥250°C											
Rated voltage	AC single-phase, 220 - 240V (order schedule)											
Set position	Bound to the winding overhang											
Connection	Two lead wires to the terminal box											
lead Marking	H1 & H2											
Wiring diagram												
Frame	100	112	132	160	180	200	225	250	280	315	355	
Rated wattage of each heating belt	30	30	40	40	50	50	60	60	60	80	110	
Quantity	1	1	1	1	1	1	1	1	1	2	2	

▼ Terminal device of protective equipment

- When the motor is installed with PTC or PTO, its wiring shall be in the main terminal box with eight-post terminal board.
- When the winding or bearing of motor is loaded with PT100, its wiring is arranged in an independent auxiliary terminal box and equipped with terminal bank.
- When the motor is only equipped with winding heating belt, its wiring is on the wall of the main terminal box. (d) When the motor is assembled with heating belt and PT100, the heating belt shall be connected on the wall of the main terminal box, and the PT100 connection shall be located in an independent auxiliary terminal box with terminal bar.
- When the motor is assembled with heating belt and PTC, the heating belt shall be connected on the wall of the main terminal box, and the PTC shall be connected on the eight-column terminal board of the main terminal box.

Ordering guide

▼ The following factors should be taken into account in motor selection:

- Voltage: 380 V 660 V 400 V 690 V Others.
- Frequency: 50 Hz 60 Hz Others.
- Mounting type: IMB3 IMB35 IMB5 IMV1 Others.
- Operating environment: Indoor Outdoor Ambient temperature Altitude
- Protection grade: IP55 IP56
- Equipment type and moment of inertia of load
- Connection mode between the motor and load
- Start mode, start frequency, start voltage drop, etc.
- Operating mode: S1 Others
- Insulation grade: 155 (F) 180(H), Nanometer insulation
- Rotation direction: Clockwise Counterclockwise Bidirectional
- Wiring box position: Top of motor Right side of motor Left side of motor (viewed from the shaft extension end)
- Energy Efficiency Level: IE5 IE4 IE3

▼ Example of demand:

- Base center height 315, 132 kW, 2P base equipped with feet, no flange at the end cover, 380/660V, clockwise rotation, IP55 rated, insulation grade F, energy efficiency level IE5.
The motor label is as follows: WE5-315M-2 132kW 380/660V 50Hz IMB3 IP55 F.
 - If you have any special requirements for voltage, frequency, protection grade, rotation direction, installation mode, dual-shaft extension, noise, vibration and wiring box connection, consult the local technical personnel for approval before manufacturing.
- ※ The data in this sample is subject to change without notice. Please pay attention to change to the sample version.

BROOK CROMPTON

a WOLONG company

WOLONG
Power your future



WOLONG ELECTRIC GROUP CO.,LTD.

Add: No. 1801 West Renmin Road, Shangyu District, Shaoxing, Zhejiang, China

Web: www.wolong.com.cn